



# 產品規格書

產品型號：SL103JPW2-F10

**PRODUCT NO. : SL103JPW2-F10**

**VERSION : Ver 1.0**

**ISSUED DATE : 2024-07-02**

This module uses ROHS material

**FOR CUSTOMER : \_\_\_\_\_**

: APPROVAL FOR SPECIFICATION

: APPROVAL FOR SAMPLE

DATE	APPROVED BY

**Solonic :**

Presented by	Reviewed by	Organized by

Note:

1.Solonic Technology Co.,Ltd. reserves the right to make changes without further notice to any products hereinto improve reliability, function or design.

2.All rights are reserved. No one is permitted to reproduce or duplicate the whole or part of this document without Solonic Technology Co., Ltd. permission.

**Record of Revisions**

Rev.	Date	Sub-Model	Description of change
1.0	Dec. 30, 2019	F10	Tentative Specification was first released.

## Contents

1.0 GENERAL DESCRIPTION .....	4
2.0 ABSOLUTE MAXIMUM RATINGS .....	5
3.0 OPTICAL CHARACTERISTICS .....	6
4.0 BLOCK DIAGRAM.....	11
5.0 INTERFACE PIN CONNECTION .....	13
6.0 ELECTRICAL CHARACTERISTICS.....	16
7.0 RELIABILITY TEST ITEMS .....	20
8.0 OUTLINE DIMENSION.....	21
9.0 LOT MARK .....	23
10.0 PACKAGE SPECIFICATION .....	24
11.0 GENERAL PRECAUTION .....	25

## 1.0 GENERAL DESCRIPTION

### 1.1 Introduction

Display model SL103JPW2-F10 is a color active matrix thin film transistor (TFT) liquid crystal display (LCD) that uses amorphous silicon TFT as a switching device.

This model is composed of a TFT LCD panel, a driving circuit and a back light system. This TFT LCD has a 10.25 inch diagonally measured active display area with HD (1920 horizontal by 720 vertical pixel) resolution.

### 1.2 Features

- 10.25 (8:3 diagonal) inch configuration
- 16.7M LVDS (two port)
- ROHS / Halogen Free Compliance

### 1.3 Applications

- Automotive

### 1.4 General information

Item	Specification	Unit	
Outline Dimension	258.9 (H) x 111.1 (V) x 7.55 (D) (Typ)	mm	
Display area	243.648(H) x 91.368(V)	mm	
Number of Pixel	1920(H) x 720(V)	pixels	
Pixel pitch	0.1269(H) x 0.1269(V)	mm	
Pixel arrangement	RGB Vertical Stripe		
Display mode	Normally Black		
NTSC	75 (Typ.)	%	
Surface treatment	HC		
Weight	330(Typ.)	g	
Back-light	Single LED (Side-Light type)		
Power Consumption	Logic System (White Pattern)	2.0 (Max)	W
	B/L System	8.91 (Max.)	W

### 1.5 Mechanical Information

Item	Min.	Typ.	Max.	Unit	
Module Size	Horizontal (H)	258.5	258.9	259.3	mm
	Vertical (V)	110.7	111.1	111.5	mm
	Depth (D)	7.15	7.55	7.95	mm
Weight	—	330	—	g	

## 2.0 ABSOLUTE MAXIMUM RATINGS

### 2.1 Electrical Absolute Rating

#### 2.1.1 TFT LCD Module

Item	Symbol	Min.	Max.	Unit	Note
Logic Supply Voltage	VDD	-0.3	+5.0	V	-

### 2.2 Environment Absolute Rating

Item	Symbol	Min.	Max.	Unit	Note
Operating Temperature	T <sub>opa</sub>	-40	85	°C	
Storage Temperature	T <sub>stg</sub>	-40	90	°C	

## 3.0 OPTICAL CHARACTERISTICS

### 3.1 Optical specification

Item		Symbol	Condition	Min.	Typ.	Max.	Unit	Note	
Contrast		CR		1000	1500	—		(1)(2)	
Response time	25°C	TR+TF	$\Theta=0$ Normal viewing angle	—	—	30	msec	(1)(3)	
	-20°C			—	—	250			
	-30°C			—	—	500			
White luminance (Center)		$Y_L$			750	1000	—	cd/m <sup>2</sup>	(1)(4) ( $I_L=300mA$ )
Color chromaticity (CIE1931)	White	$W_x$		$\pm 0.04$	$\pm 0.04$	0.313	$\pm 0.04$		(1)(4)
		$W_y$				0.329			
	Red	$R_x$				0.642			
		$R_y$				0.332			
	Green	$G_x$				0.288			
		$G_y$				0.600			
	Blue	$B_x$	0.148						
		$B_y$	0.065						
Viewing angle	Hor.	$\Theta_L$	CR>10	80	85	—			
		$\Theta_R$		80	85	—			
	Ver.	$\Theta_U$		80	85	—			
		$\Theta_D$		80	85	—			
Brightness uniformity		$B_{UNI}$	$\Theta=0$	75	80	—	%	(5)	
Optima View Direction		Free						(6)	
Reflection	%	R (%)	—	—	5.0	5.5	%	(7)	

### 3.2 Measuring Condition

- Measuring surrounding : dark room
- LED current  $I_L$  : 300mA
- Ambient temperature : 25±2°C
- 15min. warm-up time.



**Note (3)** Definition of Response Time : Sum of  $T_R$  and  $T_F$

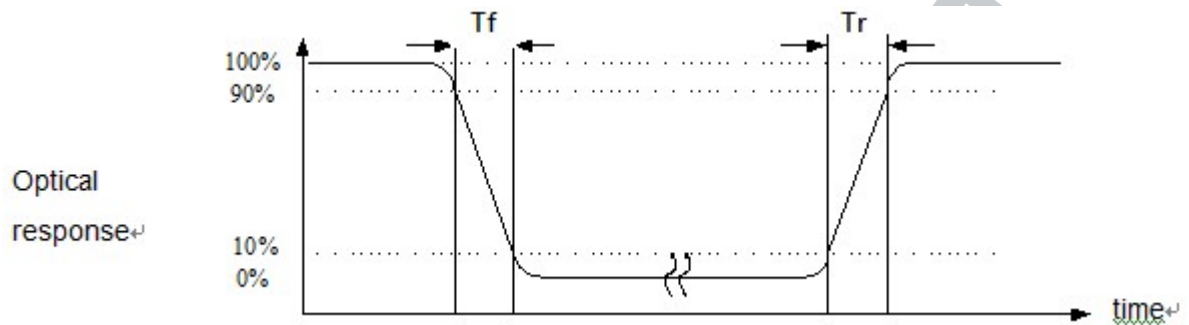

**Note (4)** Definition of optical measurement setup

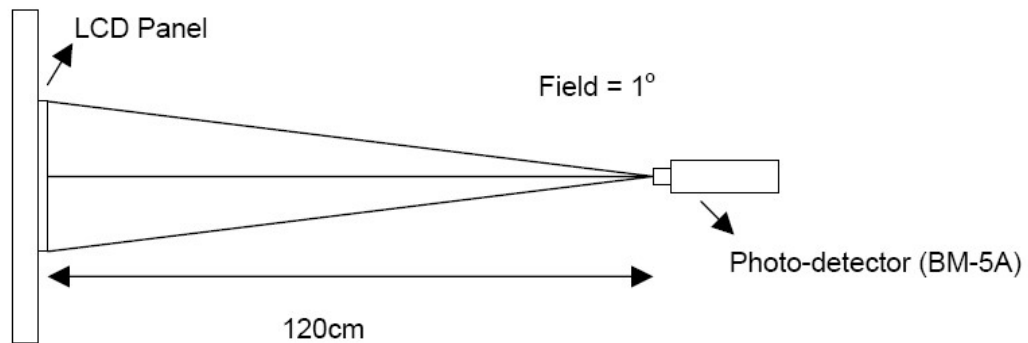

**Note (5)** Definition of brightness uniformity

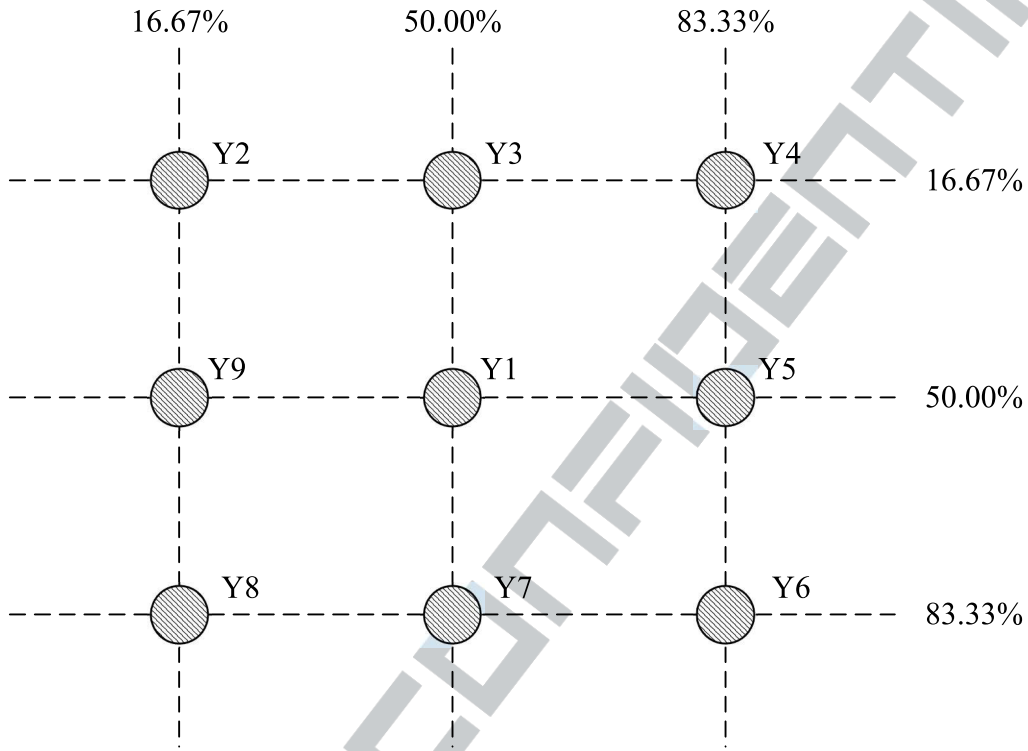

$$\text{Luminance uniformity} = \frac{(\text{Min Luminance of 9 points})}{(\text{Max Luminance of 9 points})} \times 100\%$$

**Note (6)** : Rubbing Direction (The different Rubbing Direction will cause the different optima view direction.)

**Note (7) Definition of CM-3700A(Konica Minolta) Measurement specification**

- The Settings of the instrument :
  - A. reflection rate;
  - B. Measuring the aperture: MAV(8mm);
  - C. Observer perspective: 2°;
  - D. Specular light: SCI;
  - E. The light source: D65.
  
- The definition of measurement way  
Chromatic meter will display the absorption of shaft and spectral type axial parallel alignment, and placed the sample frame for photometry.

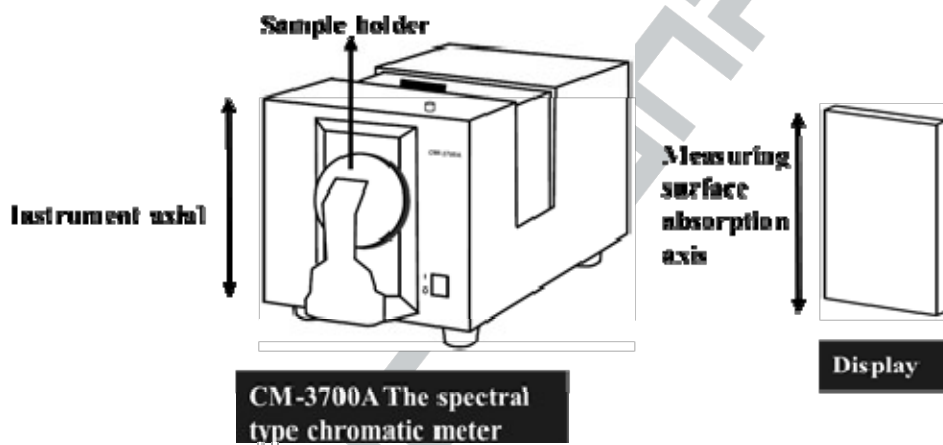

**4.0 BLOCK DIAGRAM**

**4.1 TFT LCD Module:**

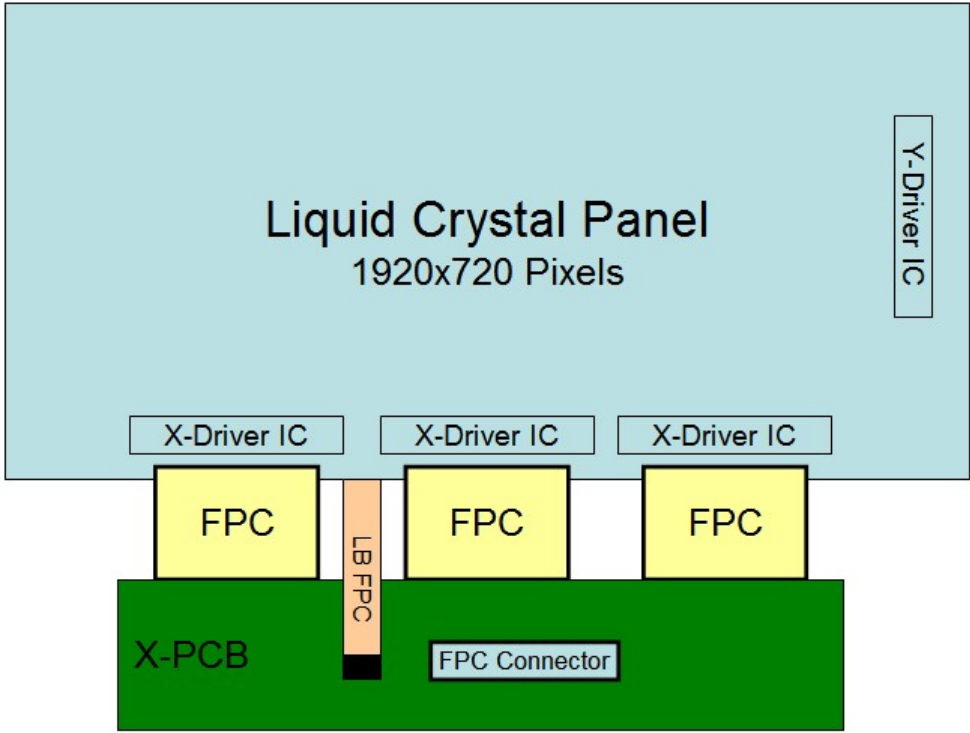

**4.2 Pixel Format**

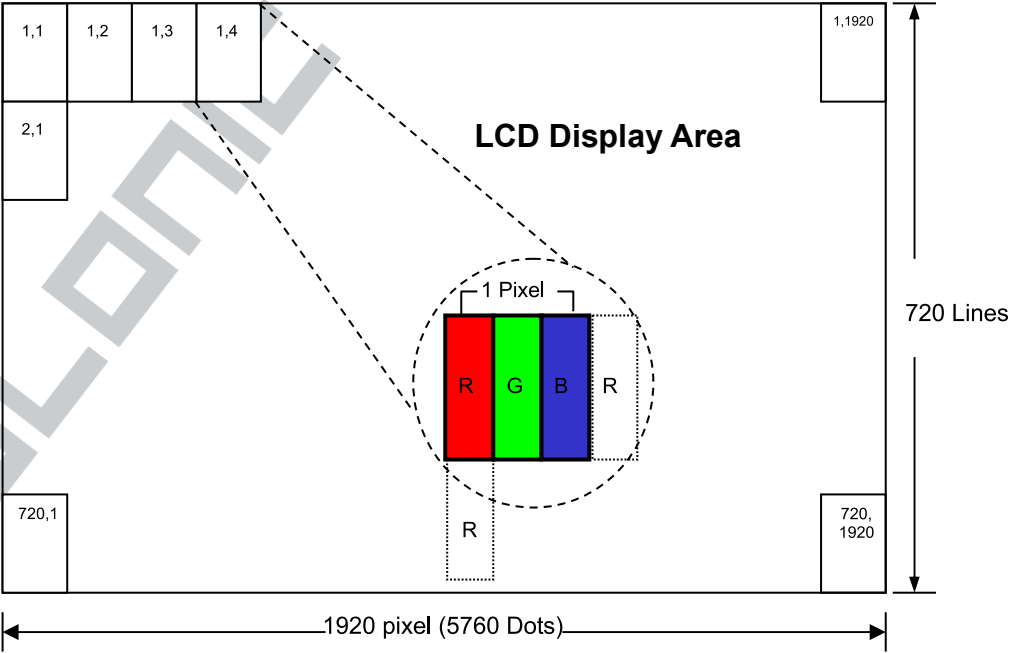

### 4.3 Relationship Between Displayed Color and Input

	Display	MSB				LSB				MSB				LSB				MSB				LSB				Gray scale Level
		R7	R6	R5	R4	R3	R2	R1	R0	G7	G6	G5	G4	G3	G2	G1	G0	B7	B6	B5	B4	B3	B2	B1	B0	
Basic color	Black	L	L	L	L	L	L	L	L	L	L	L	L	L	L	L	L	L	L	L	L	L	L	L	L	-
	Blue	L	L	L	L	L	L	L	L	L	L	L	L	L	L	L	L	H	H	H	H	H	H	H	H	-
	Green	L	L	L	L	L	L	L	L	H	H	H	H	H	H	H	H	L	L	L	L	L	L	L	L	-
	Light Blue	L	L	L	L	L	L	L	L	H	H	H	H	H	H	H	H	H	H	H	H	H	H	H	H	-
	Red	H	H	H	H	H	H	H	H	L	L	L	L	L	L	L	L	L	L	L	L	L	L	L	L	-
	Purple	H	H	H	H	H	H	H	H	L	L	L	L	L	L	L	L	H	H	H	H	H	H	H	H	-
	Yellow	H	H	H	H	H	H	H	H	H	H	H	H	H	H	H	H	L	L	L	L	L	L	L	L	-
	White	H	H	H	H	H	H	H	H	H	H	H	H	H	H	H	H	H	H	H	H	H	H	H	H	-
Gray scale of Red	Black	L	L	L	L	L	L	L	L	L	L	L	L	L	L	L	L	L	L	L	L	L	L	L	L	L0
	Dark ↑ ↓ Light	L	L	L	L	L	L	L	H	L	L	L	L	L	L	L	L	L	L	L	L	L	L	L	L	L1
		L	L	L	L	L	L	L	H	L	L	L	L	L	L	L	L	L	L	L	L	L	L	L	L	L2
		:	:	:	:	:	:	:	:	:	:	:	:	:	:	:	:	:	:	:	:	:	:	:	:	L3...L251
	H	H	H	H	H	H	L	L	L	L	L	L	L	L	L	L	L	L	L	L	L	L	L	L	L252	
	H	H	H	H	H	H	L	H	L	L	L	L	L	L	L	L	L	L	L	L	L	L	L	L	L253	
	H	H	H	H	H	H	H	L	L	L	L	L	L	L	L	L	L	L	L	L	L	L	L	L	L254	
Red	H	H	H	H	H	H	H	L	L	L	L	L	L	L	L	L	L	L	L	L	L	L	L	Red L255		
Gray scale of Green	Black	L	L	L	L	L	L	L	L	L	L	L	L	L	L	L	L	L	L	L	L	L	L	L	L	L0
	Dark ↑ ↓ Light	L	L	L	L	L	L	L	H	L	L	L	L	L	L	L	L	L	L	L	L	L	L	L	L	L1
		L	L	L	L	L	L	L	H	L	L	L	L	L	L	L	L	L	L	L	L	L	L	L	L	L2
		:	:	:	:	:	:	:	:	:	:	:	:	:	:	:	:	:	:	:	:	:	:	:	:	L3...L251
	L	L	L	L	L	L	L	L	H	H	H	H	H	L	L	L	L	L	L	L	L	L	L	L252		
	L	L	L	L	L	L	L	L	H	H	H	H	H	L	H	L	L	L	L	L	L	L	L	L253		
	L	L	L	L	L	L	L	L	H	H	H	H	H	H	L	L	L	L	L	L	L	L	L	L254		
Green	L	L	L	L	L	L	L	H	H	H	H	H	H	H	L	L	L	L	L	L	L	L	Green L255			
Gray scale of Blue	Black	L	L	L	L	L	L	L	L	L	L	L	L	L	L	L	L	L	L	L	L	L	L	L	L	L0
	Dark ↑ ↓ Light	L	L	L	L	L	L	L	L	L	L	L	L	L	L	L	L	L	L	L	L	L	L	L	H	L1
		L	L	L	L	L	L	L	L	L	L	L	L	L	L	L	L	L	L	L	L	L	L	L	H	L2
		:	:	:	:	:	:	:	:	:	:	:	:	:	:	:	:	:	:	:	:	:	:	:	:	L3...L251
	L	L	L	L	L	L	L	L	L	L	L	L	L	L	L	L	H	H	H	H	H	L	L	L	L252	
	L	L	L	L	L	L	L	L	L	L	L	L	L	L	L	L	H	H	H	H	H	L	H	L	L253	
	L	L	L	L	L	L	L	L	L	L	L	L	L	L	L	L	H	H	H	H	H	H	L	L	L254	
Blue	L	L	L	L	L	L	L	L	L	L	L	L	L	L	L	H	H	H	H	H	H	H	H	Blue L255		
Gray scale of White & Black	Black	L	L	L	L	L	L	L	L	L	L	L	L	L	L	L	L	L	L	L	L	L	L	L	L	L0
	Dark ↑ ↓ Light	L	L	L	L	L	L	L	H	L	L	L	L	L	L	L	H	L	L	L	L	L	L	L	H	L1
		L	L	L	L	L	L	L	H	L	L	L	L	L	L	H	L	L	L	L	L	L	L	H	L2	
		:	:	:	:	:	:	:	:	:	:	:	:	:	:	:	:	:	:	:	:	:	:	:	:	L3...L251
	H	H	H	H	H	L	L	H	H	H	H	H	L	L	H	H	H	H	H	L	L	L	L	L252		
	H	H	H	H	H	L	H	H	H	H	H	L	H	H	H	H	H	L	H	L	H	L	H	L253		
	H	H	H	H	H	H	L	H	H	H	H	H	L	H	H	H	H	H	L	L	L	L	L254			
White	H	H	H	H	H	H	H	H	H	H	H	H	H	H	H	H	H	H	H	H	H	H	White L255			

## 5.0 INTERFACE PIN CONNECTION

### 5.1 FPC Pin Assignment:

FPC connector is used for electronics interface. The recommended model is CN1 (Input signal): IRISO 12003S-50Y900

Pin NO.	Symbol	I/O	Description	Note
1	GND	P	Ground	
2	VDD	P	External main and I/O power supply ; +3.3V	
3	VDD	P	External main and I/O power supply ; +3.3V	
4	NC	-	Keep floating	
5	RESET	I	Global reset pin RESET="H",normal operation.(Default) RESET="L",LCM is in reset state.	
6	STBYB	I	Standby mode control. STBYB="H",normal operation. STBYB="L",LCM is in standby state.(Default)	
7	GND	P	Ground	
8	OLV0N	I	LVDS odd data 0-	
9	OLV0P	I	LVDS odd data 0+	
10	GND	P	Ground	
11	OLV1N	I	LVDS odd data 1-	
12	OLV1P	I	LVDS odd data 1+	
13	GND	P	Ground	
14	OLV2N	I	LVDS odd data 2-	
15	OLV2P	I	LVDS odd data 2+	
16	GND	P	Ground	
17	OLVCLKN	I	LVDS odd clk -	
18	OLVCLKP	I	LVDS odd clk +	
19	GND	P	Ground	
20	OLV3N	I	LVDS odd data 3-	
21	OLV3P	I	LVDS odd data 3+	
22	GND	P	Ground	
23	ELV0N	I	LVDS even data 0-	
24	ELV0P	I	LVDS even data 0+	
25	GND	P	Ground	
26	ELV1N	I	LVDS even data 1-	
27	ELV1P	I	LVDS even data 1+	
28	GND	P	Ground	

29	ELV2N	I	LVDS even data 2-	
30	ELV2P	I	LVDS even data 2+	
31	GND	P	Ground	
32	ELVCLKN	I	LVDS even clk -	
33	ELVCLKP	I	LVDS even clk +	
34	GND	P	Ground	
35	ELV3N	I	LVDS even data 3-	
36	ELV3P	I	LVDS even data 3+	
37	GND	P	Ground	
38	GND	P	Ground	
39	RL	I	Horizontal shift direction (source output) selection. RL = "H": Left -> Right(default) RL = "L": Right -> Left	
40	TB	I	Vertical shift direction (gate output) selection. TB = "H": Top ->Bottom (default) TB = "L": Bottom->Top	
41	NC	-	Keep floating	
42	NC	-	Keep floating,internal used for LCM maker.	
43	NC	-	Keep floating	
44	VDD	P	External main and I/O power supply ; +3.3V	
45	NC	-	Keep floating,internal used for LCM maker.	
46	NC	-	Keep floating,internal used for LCM maker.	
47	NC	-	Keep floating,internal used for LCM maker.	
48	NC	-	Keep floating,internal used for LCM maker.	
49	NC	-	Keep floating,internal used for LCM maker.	
50	NC	-	Keep floating,internal used for LCM maker.	

**Note 1 : TB and RL control function**

SHLR	UPDN	Data shifting
VDD	GND	Left→Right ; Down→Up
GND	GND	Right→Left ; Down→Up
VDD	VDD	Left→Right ; Up→Down(default)
GND	VDD	Right→Left ; Up→Down

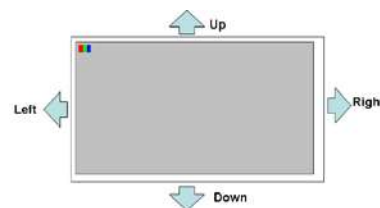

## 5.2 LED Board Pin Assignment:

CN2: IRISO 12001S-10Y901

Pin NO.	Symbol	Description
1	PLED	Power LED anode power supply
2	PLED	Power LED anode power supply
3	PLED	Power LED anode power supply
4	NC	
5	NTC1	heat sensor
6	NTC2(GND)	heat sensor
7	NLED	Power LED cathode power supply
8	NLED	Power LED cathode power supply
9	NLED	Power LED cathode power supply
10	NLED	Power LED cathode power supply

NTC: NCP18XH103F03RB

## 6.0 ELECTRICAL CHARACTERISTICS

### 6.1 TFT LCD Module

Item	Symbol	Min.	Typ.	Max.	Unit	Note
Supply Voltage	VDD	+3.0	+3.3	+3.6		Note (1)
Input Signal Voltage	$V_{IH}$	$0.7 \times VDD$	-	VDD	V	Note (2)
	$V_{IL}$	GND	-	$0.3 \times VDD$	V	
Current of VDD	IDD	-	-	600	mA	@White Pattern

Note :

(1) : VDD setting should match the signals output voltage of customer's system board.

(2) : RESET, STBYB, R/L, T/B

### 6.2 Switching Characteristics for LVDS Receiver

Item	Symbol	Min.	Typ.	Max.	Unit	Conditions
Differential Input High Threshold	$R_{xVTH}$	+100		+300	mV	
Differential Input Low Threshold	$R_{xVTL}$	-300		-100	mV	
Differential input common mode voltage	$R_{xVCM}$	1.0	1.2	$1.7 -  V_{ID} /2$	V	
Input leakage Current	$I_{IN}$	-10		10	$\mu A$	RX+/-, RXC+/-
Differential input Voltage	$ V_{ID} $	200		600	mV	

#### Single-end Signal

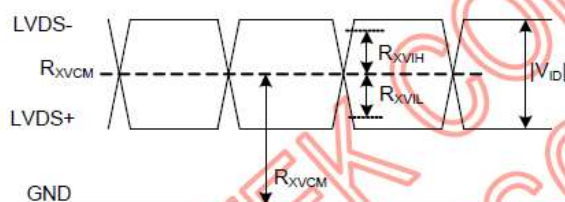

#### Differential Signal

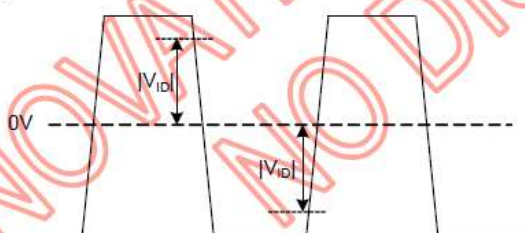

### 6.3 8Bit LVDS input

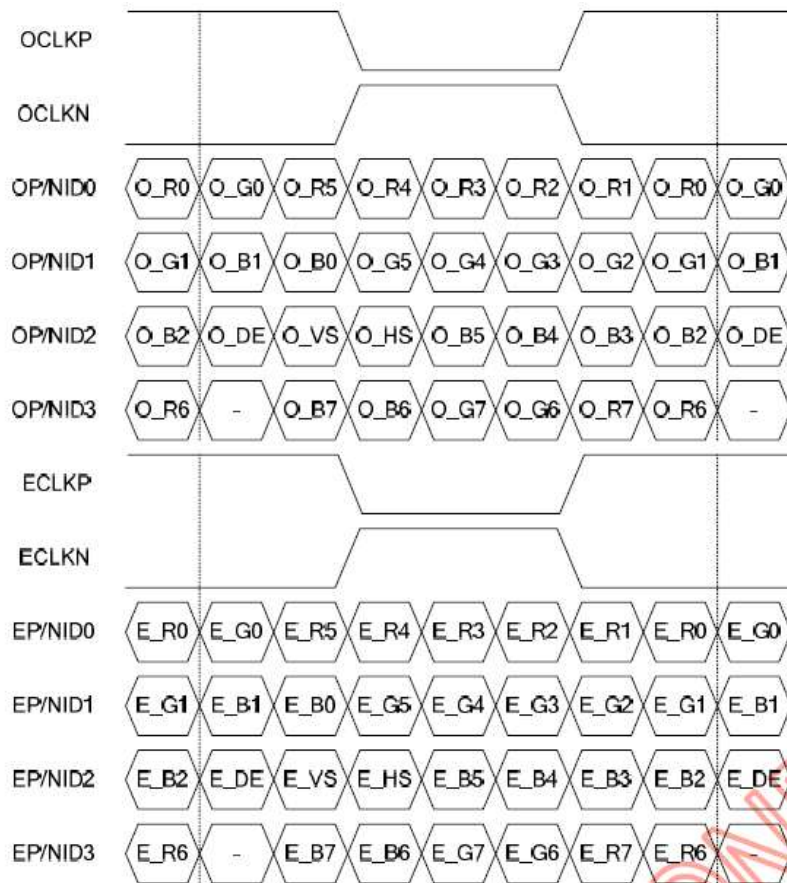

### 6.4 Interface Timing (DE mode)

Item	Symbol	Min.	Typ.	Max.	Unit
Frame Rate	--	55	60	65	Hz
Vertical Total Time	T <sub>v</sub>	730	732	764	line
Vertical Display Time	T <sub>VD</sub>	720			
Vertical Blanking Time	T <sub>VB</sub>	10	12	44	line
Horizontal Total Time	T <sub>H</sub>	1022	1045	1080	clock
Horizontal Display Time	T <sub>HD</sub>	960			
Horizontal Blanking Time	T <sub>HB</sub>	62	85	120	clock
Clock Rate	1/ T <sub>clock</sub>	45.4	45.9	48.5	MHz

## 6.5 Power On / Off Sequence

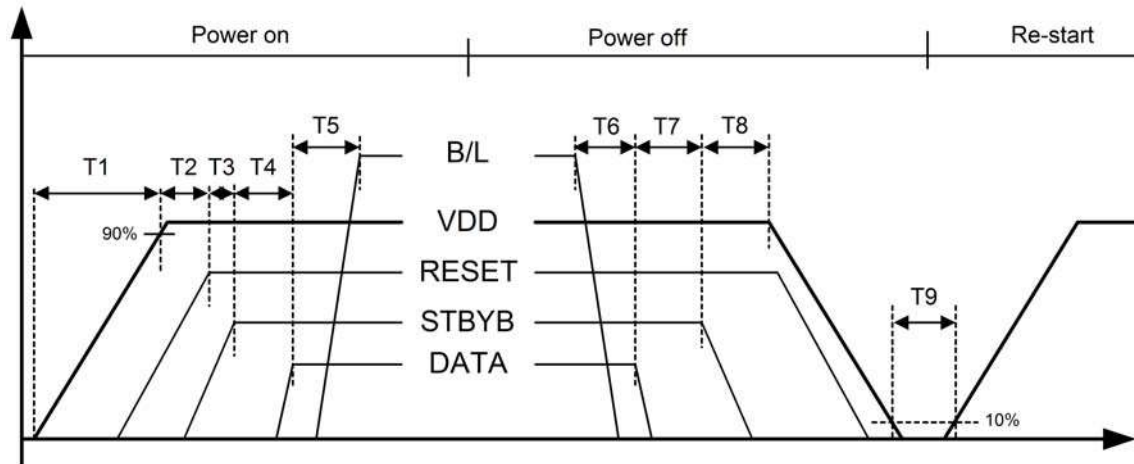

Item	Min.	Typ.	Max.	Unit
T1	0.5	--	20	ms
T2	1	--	--	ms
T3	1	--	--	ms
T4	200	--	--	ms
T5	50	--	--	ms
T6	50	--	--	ms
T7	16	--	--	ms
T8	16	--	--	ms
T9	1000	--	--	ms

## 6.6 Backlight Unit

Parameter	Symbol	Min	Typ	Max	Units	Condition
LED Current	$I_L$	--	300	--	mA	$T_a=25^\circ\text{C}$
LED Voltage	$V_L$	--	27.9	29.7	Volt	$T_a=25^\circ\text{C}$
LED Life-Time	N/A	30,000	--	--	Hour	$T_a=25^\circ\text{C}$ $I_F=75\text{mA}$ Note (2)

Note (1) LED life time (Hr) can be defined as the time in which it continues to operate under the condition:  $T_a=25\pm 3^\circ\text{C}$ , typical  $I_L$  value indicated in the above table until the brightness becomes less than 50%.

Note (2) The "LED life time" is defined as the module brightness decrease to 50% original brightness at  $T_a=25^\circ\text{C}$  and  $I_L=300\text{mA}$ . The LED lifetime could be decreased if operating  $I_L$  is larger than 300mA. The constant current driving method is suggested.

Note (3) LED Light Bar Circuit 9S4P =36pcs LED

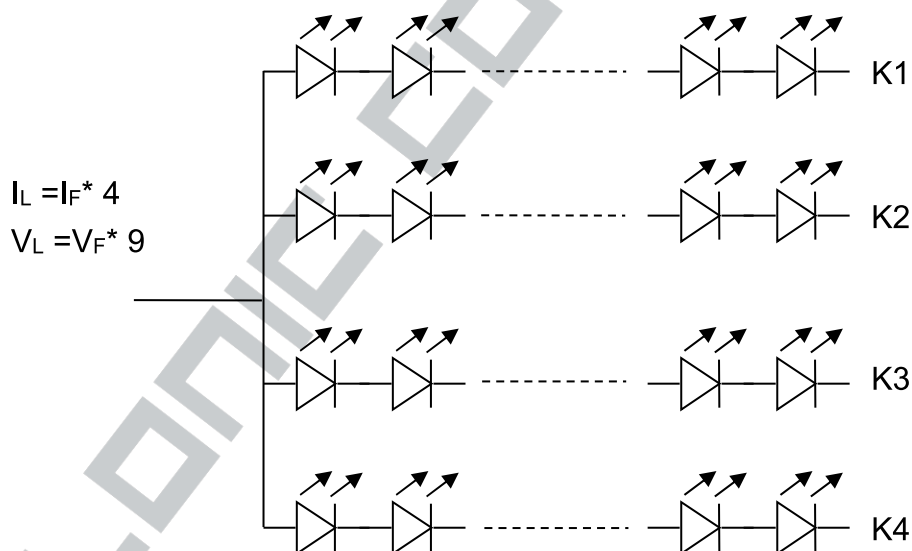

## 7.0 RELIABILITY TEST ITEMS

No.	Item	Conditions	Remark
1	High Temperature Storage	Ta=+90°C, 500hrs	1,2,3
2	Low Temperature Storage	Ta=-40°C, 500hrs	1,2,3
3	High Temperature Operation	Ta=+85°C,500hrs	1,2,3
4	Low Temperature Operation	Ta=-40°C, 500hrs	1,2,3
5	High Temperature and High Humidity (operation)	Ta=+60°C, 90%RH, 240hrs	1,2,3
6	Thermal Cycling Test (non operation)	-40°C(30min) → +85°C(30min), 100 cycles	1,2,3
7	Electrostatic Discharge	R=330Ω,C=150pF Contact = ± 8 kV, class B; Air = ± 15 kV, class B; 1 time for each point.	
8	Vibration	1.Random: 1.04G, 10~500Hz, XYZ, 30min/each direction 2.Sine: Freq.1.5G, 8~33.3Hz, Stoke: 1.3mmhz Sweep: 2.9G, 33.3~400 X/Z: 2hrs, Y:4hrs	
9	Shock	Half-Sine, 100G, 6ms, ±XYZ, 1time	
10	Vibration (with carton)	Random: 0.015G <sup>2</sup> /Hz, 5~200Hz -6dB/Octave, 200~400Hz XYZ 2hrs/each direction	
11	Drop (with carton)	Drop height condition, basis on the product weight and follow QB100-0027 1 corner, 3 edges, 6 surfaces	

Note1: There is no display function NG issue occurred, all the cosmetic specification is judged before the reliability stress.

Note2: The test result shall be evaluated after the sample has been left at room temperature and humidity for 2 hours without load. No condensation shall be accepted. The sample shall be free from defects:

(Air bubble in the LCD、Seal leak、Non-display、Missing segments、Glass crack).

Note3 : The test condition definition panel's surface temperature.

## 8.0 OUTLINE DIMENSION

Unit : mm

### 8.1 Front View:

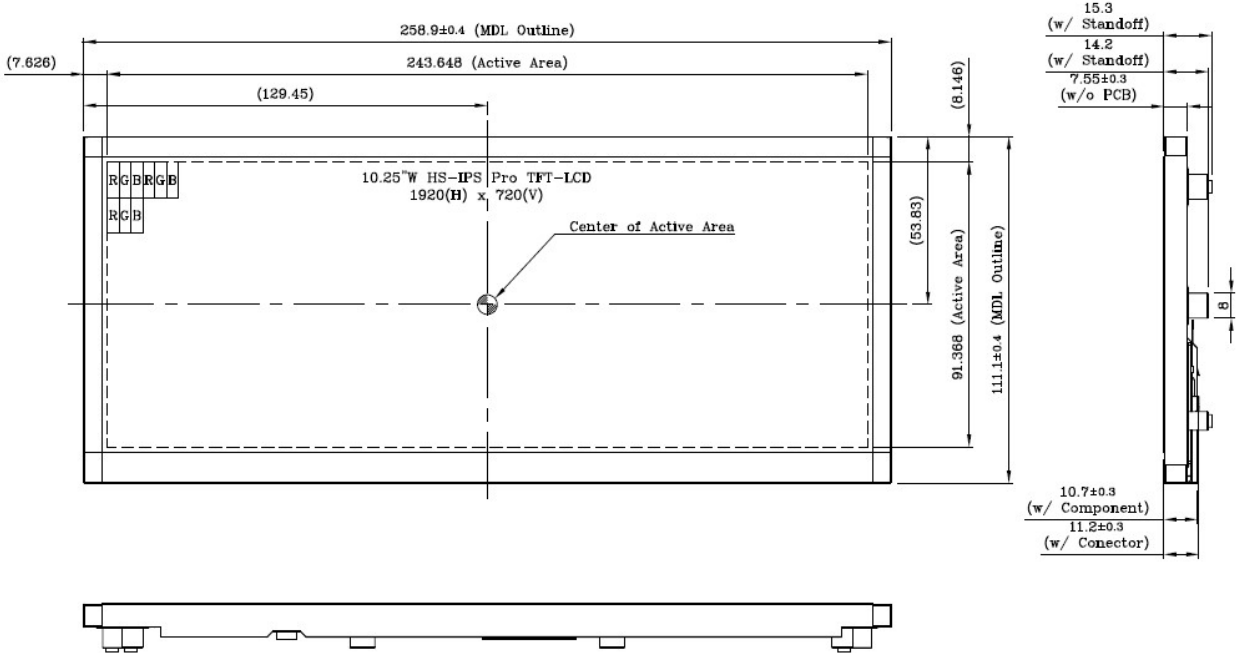



## 9.0 LOT MARK

### 9.1 Lot Mark

1	2	3	4	5	6	7	8	9	10	11	12	13	14	15
---	---	---	---	---	---	---	---	---	----	----	----	----	----	----

Code 1,2,3,4,5,6: internal flow control code.

Code 7: production location.

Code 8: production year.

Code 9: production month.

Code 10,11,12,13,14,15: serial number.

Note (1) Production Year: Code 8 is defined by the last number of the year, for example

Year	2019	2020	2021	2022	2023	2024	2025	2026	2027	2028
Mark	9	0	1	2	3	4	5	6	7	8

Note (2) Production Month

Month	Jan.	Feb.	Mar.	Apr.	May.	Jun.	Jul.	Aug.	Sep.	Oct.	Nov.	Dec.
Mark	1	2	3	4	5	6	7	8	9	A	B	C

### 9.2 Detail of Lot Mark

- (1) Below label is attached on the backside of the LCD module. See Section 8.0: Outline Dimension.
- (2) The detail of Lot Mark is attached as below.
- (3) This is subject to change without prior notice.

## 10.0 PACKAGE SPECIFICATION

### 10.1 Packing form

LCM Model	Qty. in the Box	Inner Box Size(mm)	Notice
SL103JPW2-F10-JD	20 pcs/Box	Ref. 456 x 350 x 312 <sup>H</sup>	--

### 10.2 Packing assembly drawings

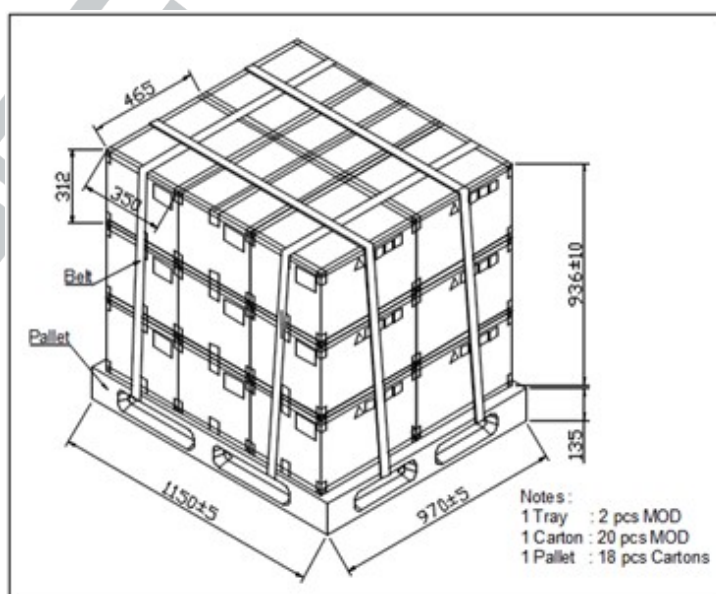
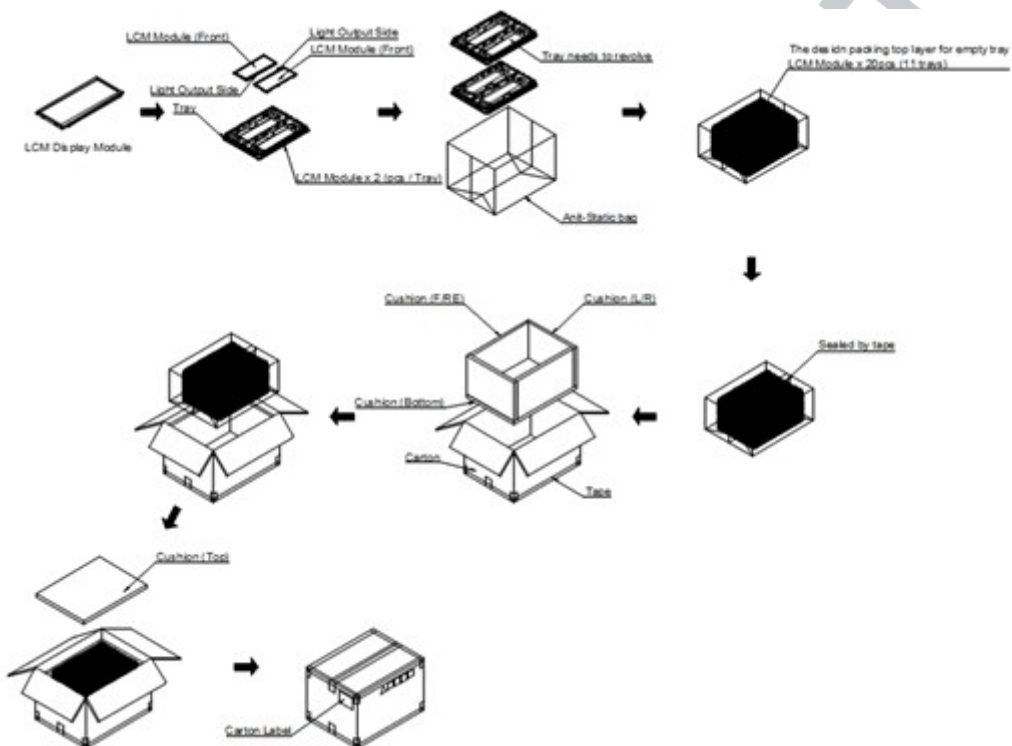

## 11.0 GENERAL PRECAUTION

### 11.1 Use Restriction

This product is not authorized for use in life supporting systems, aircraft navigation control systems, military systems and any other application where performance failure could be life-threatening or otherwise catastrophic.

### 11.2 Disassembling or Modification

Do not disassemble or modify the module. It may damage sensitive parts inside LCD module, and may cause scratches or dust on the display. does not warrant the module, if customers disassemble or modify the module.

### 11.3 Breakage of LCD Panel

11.3.1. If LCD panel is broken and liquid crystal spills out, do not ingest or inhale liquid crystal, and do not contact liquid crystal with skin.

11.3.2. If liquid crystal contacts mouth or eyes, rinse out with water immediately.

11.3.3. If liquid crystal contacts skin or cloths, wash it off immediately with alcohol and rinse thoroughly with water.

11.3.4. Handle carefully with chips of glass that may cause injury, when the glass is broken.

### 11.4 Electric Shock

11.4.1. Disconnect power supply before handling LCD module.

11.4.2. Do not pull or fold the LED cable.

11.4.3. Do not touch the parts inside LCD modules and the fluorescent LED's connector or cables in order to prevent electric shock.

### 11.5 Absolute Maximum Ratings and Power Protection Circuit

11.5.1. Do not exceed the absolute maximum rating values, such as the supply voltage variation, input voltage variation, variation in parts' parameters, environmental temperature, etc., otherwise LCD module may be damaged.

11.5.2. Please do not leave LCD module in the environment of high humidity and high temperature for a long time.

11.5.3. It's recommended to employ protection circuit for power supply.

### 11.6 Operation

11.6.1 Do not touch, push or rub the polarizer with anything harder than HB pencil lead.

11.6.2 Use fingerstalls of soft gloves in order to keep clean display quality, when persons handle the LCD module for incoming inspection or assembly.

11.6.3 When the surface is dusty, please wipe gently with absorbent cotton or other soft material.

11.6.4 Wipe off saliva or water drops as soon as possible. If saliva or water drops contact with polarizer for a long time, they may causes deformation or color fading.

11.6.5 When cleaning the adhesives, please use absorbent cotton wetted with a little petroleum benzine or other adequate solvent.

## **11.7 Mechanism**

Please mount LCD module by using mounting holes arranged in four corners tightly.

## **11.8 Static Electricity**

11.8.1 Protection film must remove very slowly from the surface of LCD module to prevent from electrostatic occurrence.

11.8.2 Because LCD module use CMOS-IC on circuit board and TFT-LCD panel, it is very weak to electrostatic discharge. Please be careful with electrostatic discharge. Persons who handle the module should be grounded through adequate methods.

## **11.9 Strong Light Exposure**

The module shall not be exposed under strong light such as direct sunlight. Otherwise, display characteristics may be changed.

## **11.10 Disposal**

When disposing LCD module, obey the local environmental regulations.