



產品規格書

產品型號：SL-12.3-1920720-EWMN-01

PRODUCT NO. : SL-12.3-1920720-EWMN-01

VERSION : Ver 1.7

ISSUED DATE : 2024-07-03

This module uses ROHS material

FOR CUSTOMER : _____

: APPROVAL FOR SPECIFICATION

: APPROVAL FOR SAMPLE

DATE	APPROVED BY

Solonic :

Presented by	Reviewed by	Organized by

Note:

1.Solonic Technology Co.,Ltd. reserves the right to make changes without futher notice to any products

hereinto improve reliability, function or design.

2.All rights are reserved. No one is permitted to reproduce or duplicate the whole or part of this document

without Solonic Technology Co., Ltd. permission.

Revision History

Revision	Date	Originator	Detail	Remarks
Ver 1.0	20231108		Initial Release	
Ver 1.1	20240326			
Ver 1.2	20240327			
Ver 1.3	20240402			
Ver 1.4	20240524			
Ver 1.5	20240613			
Ver 1.6	20240626			
Ver 1.7	20240703			

Table of Contents

No.	Item	Page
1.	General Description.....	5
2.	Module Parameter.....	5
3.	Absolute Maximum Ratings.....	7
4.	DC Characteristics.....	8
5.	Backlight Characteristic.....	8
5.1.	Backlight Characteristic.....	8
5.2.	Backlighting circuit.....	8
6.	Optical Characteristics.....	9
6.1.	Optical Characteristics.....	9
6.2.	Definition of Response Time.....	9
6.3.	Definition of Contrast Ratio.....	10
6.4.	Definition of Viewing Angles.....	11
6.5.	Definition of Color Appearance.....	11
6.6.	Definition of Surface Luminance, Uniformity and Transmittance.....	11
7.	Block Diagram and Power Supply.....	12
8.	Interface Pins Definition (Connector Type: 196479-40041-3).....	14
9.	AC Characteristics.....	16
9.1.	AC Electrical Characteristics.....	16
9.2.	Timing.....	16
9.3.	Timing.....	17

9.4. Power sequence	18
10. Quality Assurance	20
10.1. Purpose.....	20
10.2. Standard for Quality Test.....	20
10.3. Nonconforming Analysis & Disposition.....	20
10.4. Agreement Items	20
10.5. Standard of the Product Visual Inspection	21
10.6. Inspection Specification.....	21
10.7. Classification of Defects	26
10.8. Identification/marketing criteria.....	26
10.9. Packing	26
11. Reliability Specification.....	27
12. Precautions and Warranty	28
12.1. Safety	28
12.2. Handling.....	28
12.3. Storage.....	28
12.4. Metal Pin (Apply to Products with Metal Pins).....	28
12.5. Operation	29
12.6. Static Electricity	29
12.7. Limited Warranty	30
13. Packaging	31

1. General Description

The specification is a transmissive type color active matrix liquid crystal display (LCD) which uses amorphous thin film transistor (TFT) as switching devices. This product is composed of a TFT-LCD panel, driver ICs , and a backlight unit.

2. Module Parameter

Features	Details	Unit
Display Size(Diagonal)	12.3"	
LCD type	IPS TFT	
Display Mode	Transmissive /Normally Black	
Resolution	1920 RGB x 720	Pixels
View Direction	FULL VIEWING	Best Image
Module Outline	310 (H)x 128(V) x 7.0(T) (Note1)	mm
Active Area	292.032 (H) x 109.512(V)	mm
Pixel Pitch	152.1 (H)x 152.1(V)	um
Pixel Arrangement	RGB Vertical stripe	
Polarizer Surface Treatment	Black/Glare	
Display Colors	16.7M	
Interface	8 bits-D-LVDS interface	
Driver IC	-	
With or without the touch panel	Without	
Operating Temperature	-30~85	℃
Storage Temperature	-40~90	℃
Weight	477.5	g

Note 1: Inclusive hooks, posts, FFC/FPC tail etc.

3. Absolute Maximum Ratings

The followings are maximum values which, if exceed, may cause faulty operation or damage to the unit. The operational and non-operational maximum voltage and current values are listed in Table.

$V_{SS}=0V, T_a=25^{\circ}C$

Item	Symbol	Min.	Max.	Unit
Supply Voltage	VDD	3.0	3.6	V
Supply Current	VDD		550	mA
Storage temperature	T_{STG}	-40	+90	$^{\circ}C$
Operating temperature	T_{OP}	-30	+85	$^{\circ}C$

Note 1: If T_a below $50^{\circ}C$, the maximal humidity is 90%RH, if T_a over $50^{\circ}C$, absolute humidity should be less than 60%RH.

Note 2: The response time will be extremely slow when the operating temperature is around $-10^{\circ}C$, and the back ground will become darker at high temperature operating.

Note 3: These range above is maximum value not the actual operating temperature . Actual Operating temperature is no more than $40^{\circ}C$ and temperature refers to the LCM surface temperature ;

Note 4: Solonic is not responsible for product problems beyond the use conditions.

Note 5: Temperature and relative humidity range are shown in the figure below. Wet bulb temperature should be $39^{\circ}C$ max. and no condensation of water.

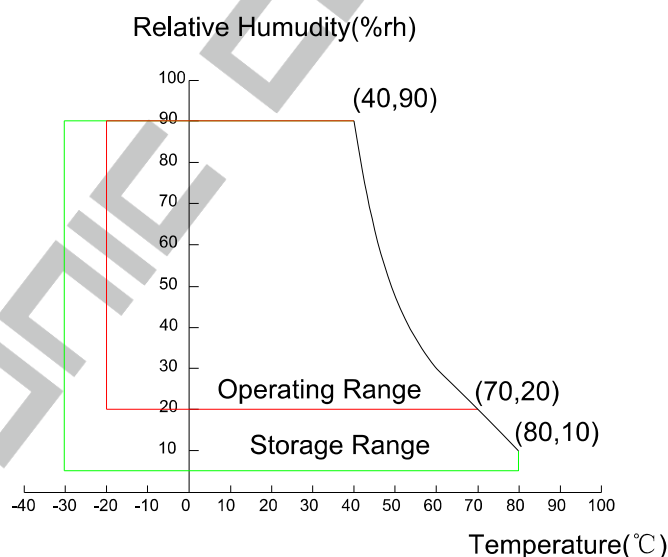

4. DC Characteristics

Item	Symbol	Min.	Typ.	Max.	Unit
Supply Voltage/current	VDD	3.0	3.3	3.6	V
Logic Low input voltage	V _{IL}	0	-	0.3*VDD	V
Logic High input voltage	V _{IH}	0.7*VDD	-	VDD	V

Note 1: All of the voltage listed above are with respect to GND = 0v

Note 2: Device is subject to be damaged permanently if stresses beyond those absolute maximum rating listed above

5. Backlight Characteristic

5.1. Backlight Characteristic

Item	Symbol	Condition	Min.	Typ.	Max.	Unit
Forward Voltage	V _F	T _a =25 °C, I _F =60mA/LED	21	-	26	V
Forward Current	I _F	T _a =25 °C, V _F =3V/LED	-	360	-	mA
Power dissipation	P _D	-	7560	-	9360	mW
Uniformity	Avg		70	80	-	%
LED working life(25°C)	-		30000	-	-	Hrs
Drive method	Constant current					
LED Configuration	48White LEDs(8 LEDs in one string and 6 groups in parallel)					

Note1: LED life time defined as follows: The final brightness is at 50% of original brightness.

The environmental conducted under ambient air flow, at T_a=25 ± 2 °C, 60%RH ± 5%, I_F=20mA.

5.2. Backlighting circuit



6. Optical Characteristics

6.1. Optical Characteristics

Ta=25°C, DVDD=3.3V

Backlight On (Transmissive Mode)	Item	Symbol	Condition	Specification			Unit	
				Min.	Typ.	Max.		
	Luminance on TFT($I_f=21\text{mA/LED}$)	Lv	Center CR ≥ 10	640	800	-	cd/m ²	
	Contrast ratio(See 6.3)	CR			1000	-		
	Response time (See 6.2)	TR+TF		-	30	35	ms	
	Chromaticity Transmissive (See 6.5)	White		Xw	0.253	0.303	0.353	
			Yw	0.301	0.351	0.401		
	Viewing Angle (See 6.4)	Horizontal	θ_{x+}	Center CR ≥ 10	80	88	-	Deg.
			θ_{x-}		80	88	-	
		Vertical	φ_{y+}		80	88	-	
			φ_{y-}		80	88	-	
	NTSC Ratio(Gamut)				65	70	-	%

6.2. Definition of Response Time

6.2.1. Normally Black Type (Negative)

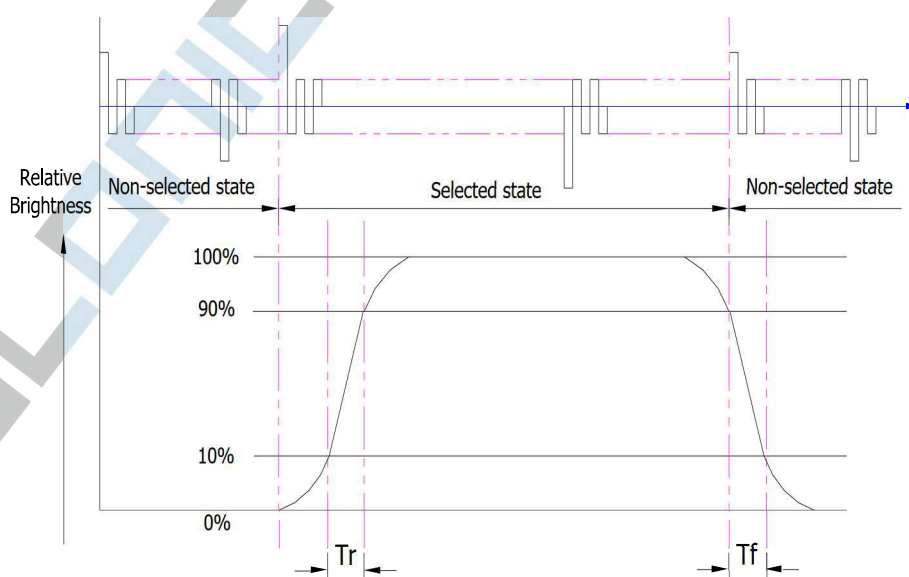

T_r is the time it takes to change from non-selected stage with relative luminance 10% to

selected state with relative luminance 90%;

Tf is the time it takes to change from selected state with relative luminance 90% to non-selected state with relative luminance 10%.

Note: Measuring machine: LCD-5100

6.2.2. Normally White Type (Positive)

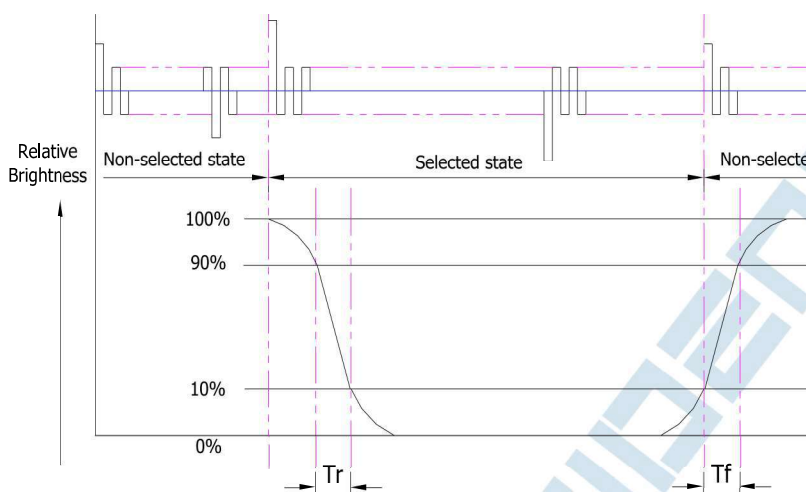

Tr is the time it takes to change from non-selected stage with relative luminance 90% to selected state with relative luminance 10%;

Tf is the time it takes to change from selected state with relative luminance 10% to non-selected state with relative luminance 90%;

Note: Measuring machine: LCD-5100 or EQUI

6.3. Definition of Contrast Ratio

Contrast is measured perpendicular to display surface in reflective and transmissive mode. The measurement condition is:

Measuring Equipment	Eldim or Equivalent
Measuring Point Diameter	3mm//1mm
Measuring Point Location	Active Area centre point
Test pattern	A: All Pixels white
	B: All Pixel black
Contrast setting	Maximum

Definitions: CR (Contrast) = Luminance of White Pixel / Luminance of Black Pixel

6.4. Definition of Viewing Angles

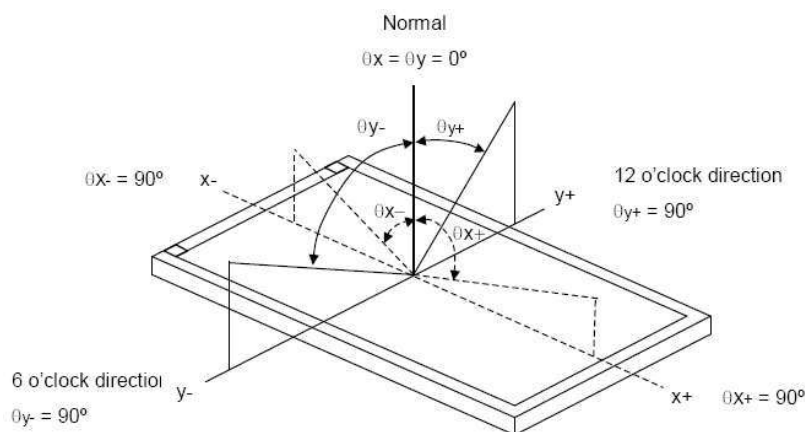

Measuring machine: LCD-5100 or EQUI

6.5. Definition of Color Appearance

R,G,B and W are defined by (x, y) on the IE chromaticity diagram

NTSC=area of RGB triangle/area of NTSC triangleX100%

Measuring picture: Red, Green, Blue and White (Measuring machine: BM-7)

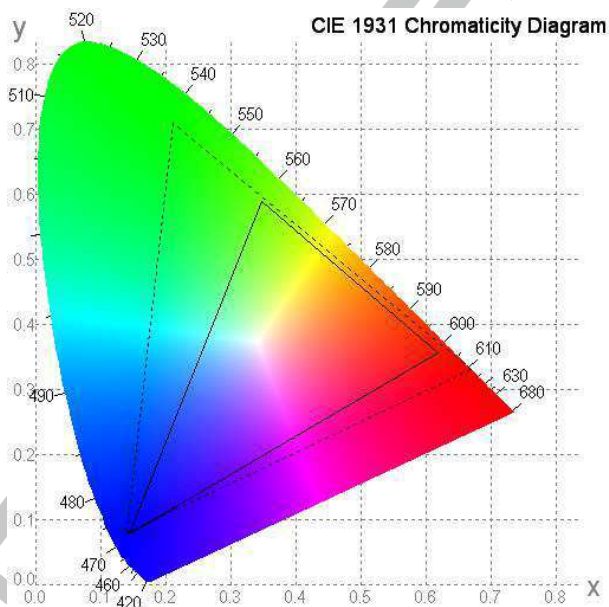

6.6. Definition of Surface Luminance, Uniformity and Transmittance

Using the transmissive mode measurement approach, measure the white screen luminance of the display panel and backlight.

6.6.1. Surface Luminance: $L_v = \text{average}(L_{P1}:L_{P9})$

6.6.2. Uniformity = Minimal ($L_{P1}:L_{P9}$) / Maximal ($L_{P1}:L_{P9}$) * 100%

6.6.3. Transmittance = L_v on LCD / L_v on Backlight * 100%

Note: Measuring machine: BM-7

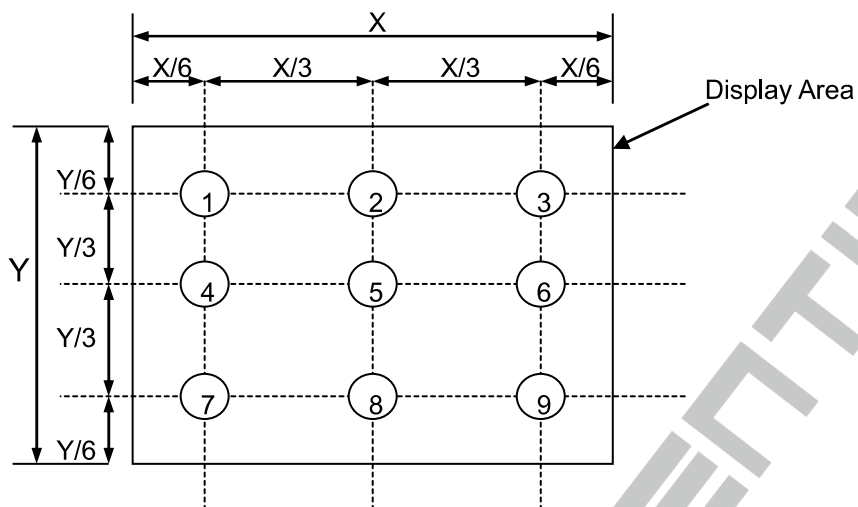

7. Block Diagram and Power Supply

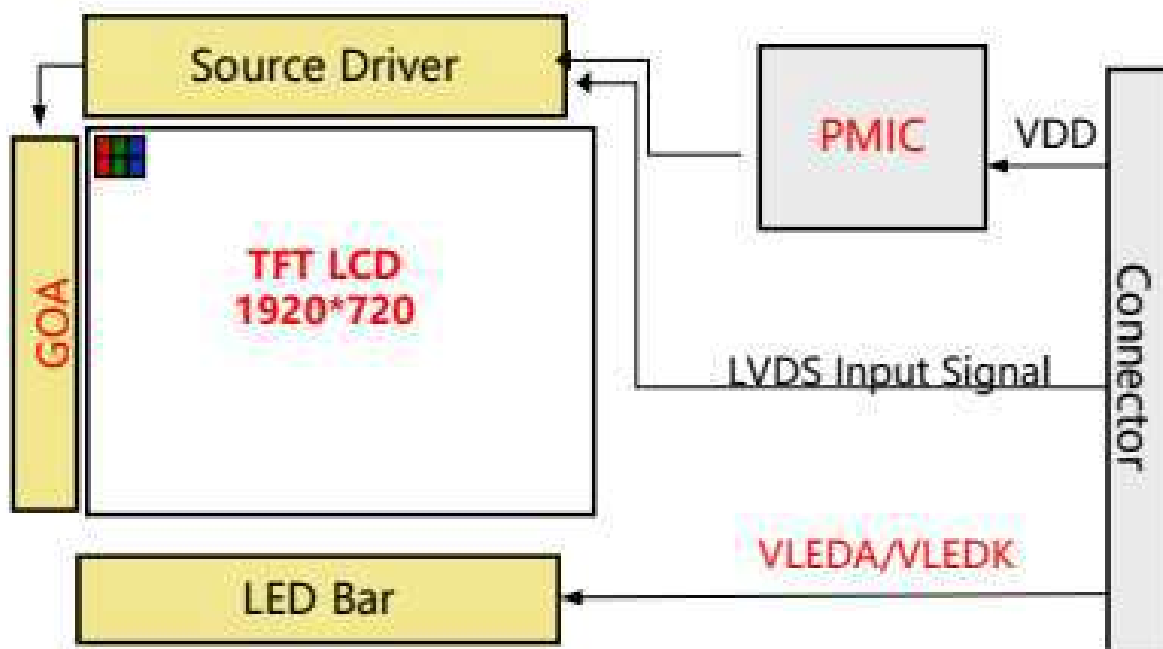

8. Interface Pins Definition

PIN	SYMBOL	Description	Remark
1	NC	NO CONNECTION	BOE for VDDOTP
2	GND	Ground	
3	GND	Ground	
4	GND	Ground	
5	NC	NO CONNECTION	
6	VDD	Power Supply	
7	VDD	Power Supply	
8	VDD	Power Supply	
9	NC	NO CONNECTION	
10	NC	NO CONNECTION	BOE for ATREN
11	GND	Ground	
12	GND	Ground	
13	ORXIN0-	LVDS Receiver Signal(-)	
14	ORXIN0+	LVDS Receiver Signal(+)	
15	GND	Ground	
16	ORXIN1-	LVDS Receiver Signal(-)	
17	ORXIN1+	LVDS Receiver Signal(+)	
18	GND	Ground	
19	ORXIN2-	LVDS Receiver Signal(-)	
20	ORXIN2+	LVDS Receiver Signal(+)	
21	GND	Ground	
22	ORXCLKIN-	LVDS Receiver Signal(-)	
23	ORXCLKIN+	LVDS Receiver Signal(+)	
24	GND	Ground	

PIN	SYMBOL	Description	Remark
25	ORXIN3-	LVDS Receiver Signal(-)	
26	ORXIN3+	LVDS Receiver Signal(+)	
27	GND	Ground	
28	ERXIN0-	LVDS Receiver Signal(-)	
29	ERXIN0+	LVDS Receiver Signal(+)	
30	GND	Ground	
31	ERXIN1-	LVDS Receiver Signal(-)	
32	ERXIN1+	LVDS Receiver Signal(+)	
33	GND	Ground	
34	ERXIN2-	LVDS Receiver Signal(-)	
35	ERXIN2+	LVDS Receiver Signal(+)	
36	GND	Ground	
37	ERXCLKIN-	LVDS Receiver Signal(-)	
38	ERXCLKIN+	LVDS Receiver Signal(+)	
39	GND	Ground	
40	ERXIN3-	LVDS Receiver Signal(-)	
41	ERXIN3+	LVDS Receiver Signal(+)	
42	GND	Ground	
43	STBYB	STBYB Signal	L:Standby H:Normal
44	RESET	RESET Signal	L:Reset H:Normal
45	CSB	SPI Signal	
46	NC	NO CONNECTION	
47	SCL	SPI Signal	
48	SDA	SPI Signal	
49	NC	NO CONNECTION	
50	GND	Ground	



9. SIGNAL SPECIFICATION

9.1. LVDS Signal Timing

Table 10-1 LVDS Signal Timing(DE Mode)

Parameter	Symbol	Min.	Typ.	Max.	Unit	Condition
Clock frequency	RxFCLK	43.1	45.7	70.1	MHz	Note1
Horizontal Display Area	thd	960			DCLK	
HS Period	th	989	1002	1248	DCLK	
HS Blanking	Thb+thfp		42		DCLK	
Vertical Display Area	tvd	720			TH	
VS Period	tv	727	760	936	TH	
VS Blanking	Tvbp+tvfp		40		TH	
Frame Rate	FR	60	60	60	Hz	
Clock period	TLVCYC	14.28			ns	
Clock high time	TLVCH		4		UI	
Clock low time	TLVCL		3		UI	
LVDS wake-up time	T _{ENLVDS}			150	us	

Note 1: Advise the customer to use the Typ. value

9.2 Signal Format

Table 10-2 2-port LVDS signals, VESA format, 8-bit mode

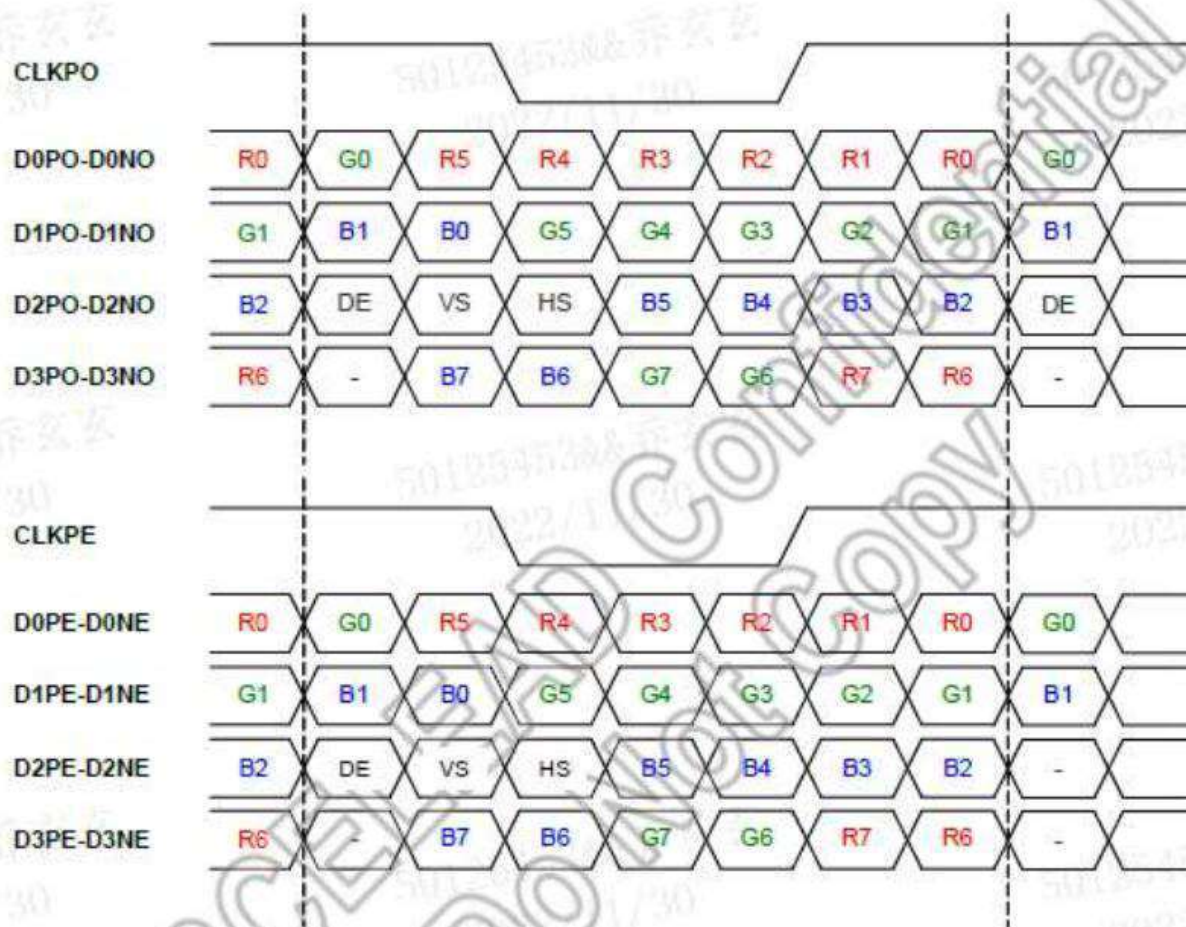

Note:

1. For 6 bit mode, MSB are R/G/B[5] and LSB are R/G/B[0]
2. For 8 bit mode, MSB are R/G/B[7] and LSB are R/G/B[0]
3. For single port LVDS only ODD port (CLKxO and DxxO) are used

9.3 LVDS DC Characteristics

Parameter	Symbol	Min	Typ.	Max.	Unit	Conditions
Differential input high threshold voltage	R_{xVTH}			0.1	V	$R_{xVCM} = 1.2V$
Differential input low threshold voltage	R_{xVTL}	-0.1			V	
Input voltage range (singled-end)	R_{xVIN}	0		$V_{DD}-1.2$	V	
Differential input common mode voltage	R_{xVCM}	0.8	1.2	1.4	V	
Differential input voltage	$ V_{ID} $	0.2	0.4	0.6	V	
Differential input leakage current	$R_{V_{xIz}}$	-10		10	μA	

Differential signals

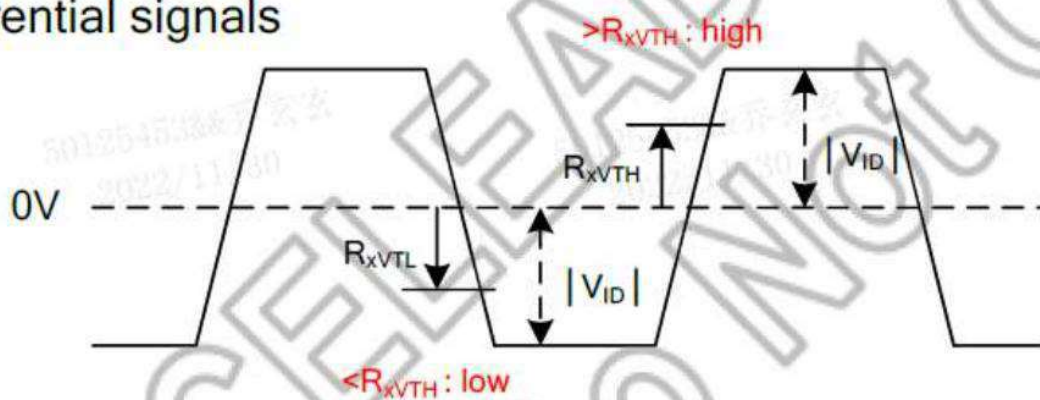

9.4 LVDS AC Characteristics

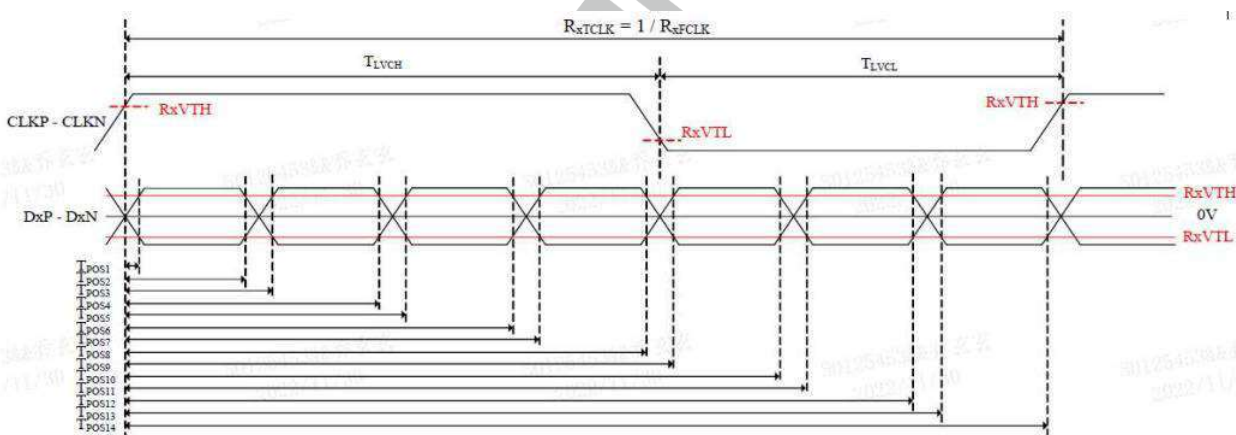

9.4 POWER ON/OFF SEQUENCE

9.4.1 POWER ON SEQUENCE

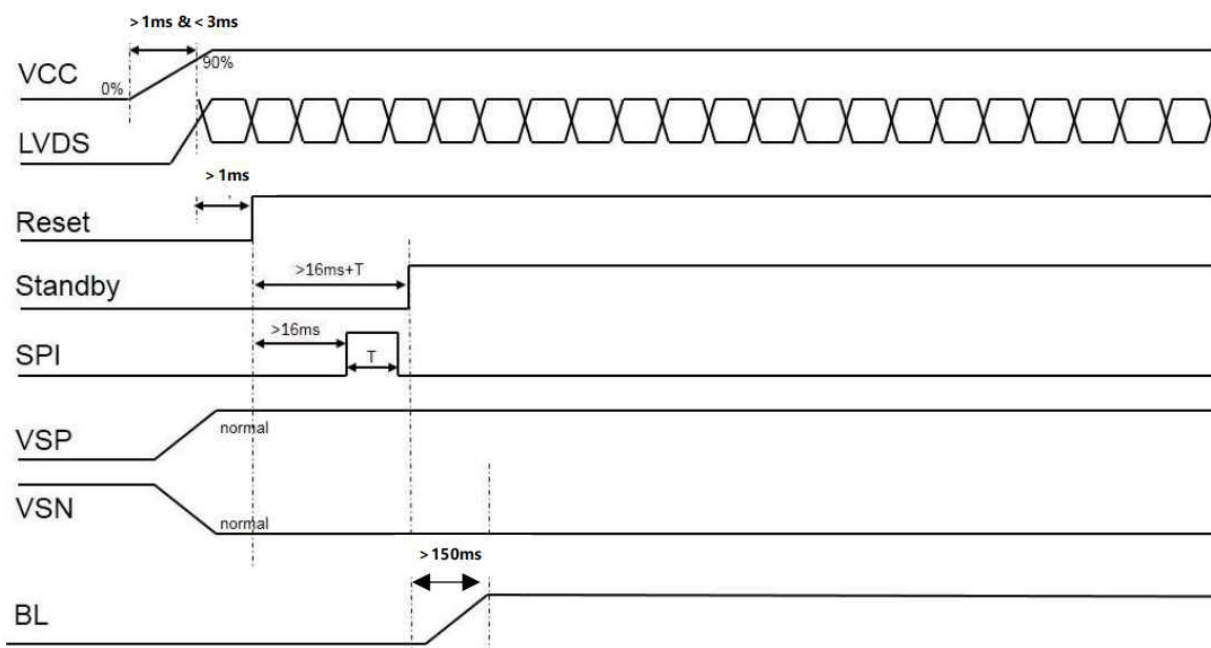

9.4.2 POWER OFF SEQUENCE

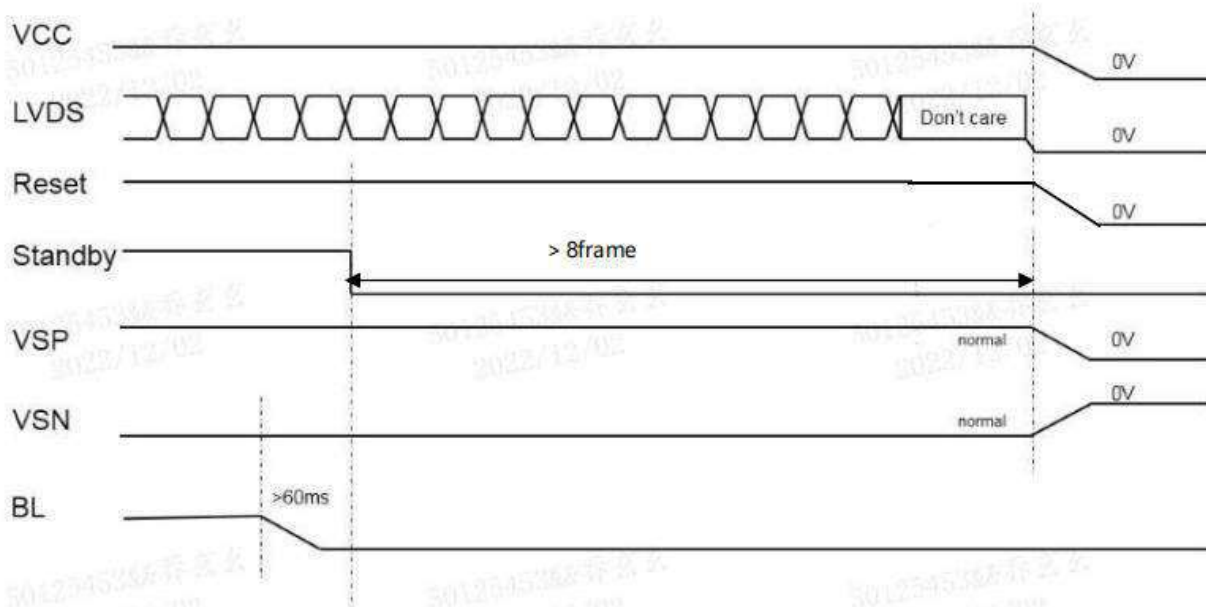

Note: Reset 可与 VDD 下电同步

10. Quality Assurance

10.1.Purpose

This standard for Quality Assurance assures the quality of LCD module products supplied to customer.

10.2.Standard for Quality Test

10.2.1. Sampling Plan:

GB2828.1-2012

Single sampling, general inspection level II

10.2.2. Sampling Criteria:

Visual inspection: AQL 1.5%

Electrical functional: AQL 0.65%.

10.2.3. Reliability Test:

Detailed requirement refer to Reliability Test Specification.

10.3.Nonconforming Analysis & Disposition

10.3.1. Nonconforming analysis:

10.3.1.1. Customer should provide overall information of non-conforming sample for their complaints.

10.3.1.2. After receipt of detailed information from customer, the analysis of nonconforming parts usually should be finished in one week.

10.3.1.3. If cannot finish the analysis on time, customer will be notified with the progress status.

10.3.2. Disposition of nonconforming:

10.3.2.1. Non-conforming product over PPM level will be replaced.

10.3.2.2. The cause of non-conformance will be analyzed. Corrective action will be discussed and implemented.

10.4.Agreement Items

Shall negotiate with customer if the following situation occurs:

10.4.1. There is any discrepancy in standard of quality assurance.

10.4.2. Additional requirement to be added in product specification.

10.4.3. Any other special problem.

10.5. Standard of the Product Visual Inspection

10.5.1. Appearance inspection:

10.5.1.1. The inspection must be under illumination about 1000 – 1500 lx, and the distance of view must be at 30cm ± 2cm.

10.5.1.2. The viewing angle should be 45° from the vertical line without reflection light or follows customer's viewing angle specifications.

10.5.1.3. Definition of area: A Zone: Active Area, B Zone: Viewing Area,

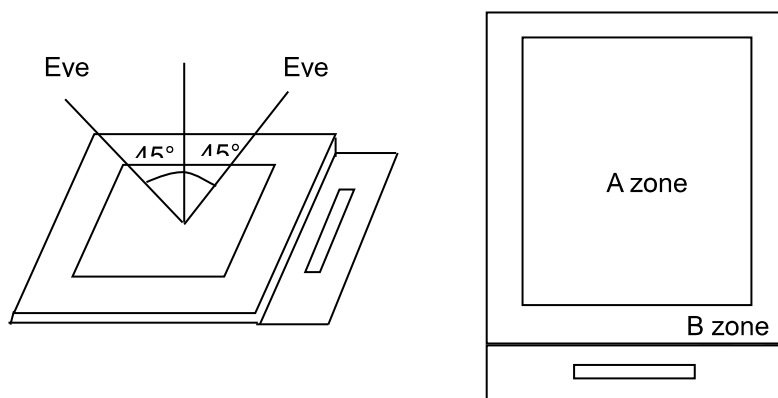

10.5.2. Basic principle:

10.5.2.1. A set of sample to indicate the limit of acceptable quality level must be discussed by both us and customer when there is any dispute happened.

10.5.2.2. New item must be added on time when it is necessary.

10.6. Inspection Specification

These inspection standards shall be applied to LCD Module supplied by INNOLUX Optoelectronics Corporation. This model is only used in CE product, if it is used in other product applications; it still adopts this copy of specification. If there are any other product applications such as handwriting recognition, Industrial use, Medical use, Aerospace usage and so on, the specifications should be negotiated separately.

01 Definition of dot defect induced from the panel inside

a) Bright dot: Dots appear bright and unchanged in size in which LCD panel is displaying under black pattern.

b) Dark dot: Dots appear dark and unchanged in size in which LCD panel is displaying under pure red, green, blue picture.

c) 2 dot adjacent = 1 pair = 2 dots

Picture:

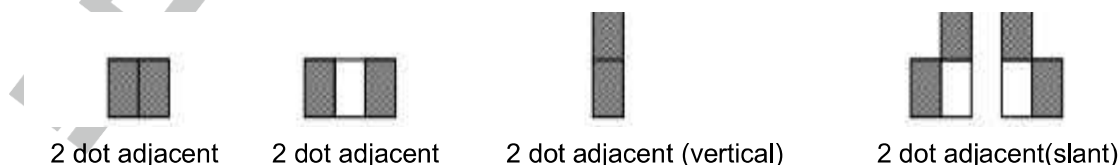

No.	Display Inspection		
02	Items		Criteria (Unit: mm)
	Bright dot	Random	$N \leq 3$
		2 dots adjacent	$N \leq 0$
		3 dots adjacent	$N \leq 0$
	Dark dot	Random	$N \leq 4$
		2 dots adjacent	$N \leq 0$
		3 dots adjacent	$N \leq 0$
	Total bright dot and dark dot		$N \leq 6$
Distance	Minimum Distance Between dark dots Minimum Distance Between dark and bright dots	5mm	
Tiny bright dot		visible through 5% ND filter $D \leq 0.3\text{mm}$, Ignore $0.3\text{mm} < D \leq 0.5\text{mm}$, $N \leq 4$ Distance $\geq 5\text{mm}$	
Display failure (V-line/Cross line etc)			
Mura/Waving/Hot spot	Not visible through 6% ND filter in 50% gray or judge by limit sample if necessary		

*Note: Defect which is on the Black Matrix (outside of Active Area) are not considered as a defect.

No.	Appearance & Display inspection	
03	Items	Criteria (Unit: mm)
	Foreign Black/White/Bright Spot (Display & Appearance)	$D \leq 0.3\text{mm}$, Ignore, $0.3\text{mm} < D \leq 0.5\text{mm}$, $N \leq 4$ Distance $\geq 5\text{mm}$, It is shown in Fig. 2.
	Foreign Black/White/Bright Line (Display & Appearance)	$W \leq 0.07\text{ mm}$, Ignore $0.07 < W \leq 0.1\text{ mm}$ $L \leq 5.0\text{ mm}$, $N \leq 4$ It is shown in Fig. 3.
	Polarizer Dent/Air Bubble	$D \leq 0.3\text{mm}$, Ignore $0.3\text{mm} < D \leq 0.5\text{mm}$, $N \leq 4$ Distance $\geq 5\text{mm}$
	Polarizer Scratches	$W \leq 0.07\text{ mm}$, Ignore $0.07 < W \leq 0.1\text{mm}$ $L \leq 5.0\text{ mm}$, $N \leq 4$

Notes: If any specific defect is not included in the above defect table, this defect should be judged by INX/ODM/Brand customer discussion.

- 1. W: Width 3. D: Average Diameter
- 2. L: Length 4. N: Count

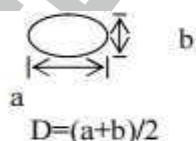
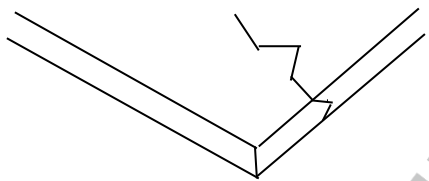
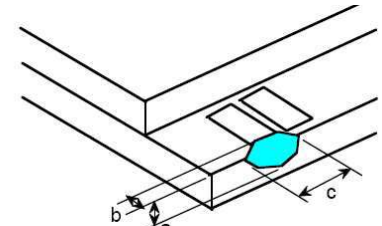
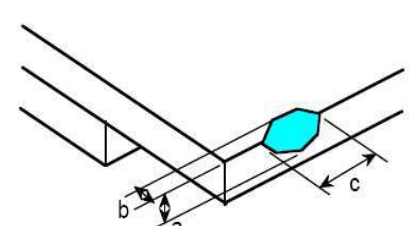
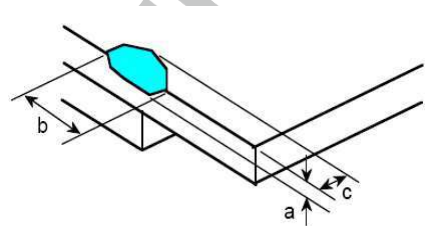

Fig. 2



W: width, L: length

Fig. 3

No.	Item	Criteria (Unit: mm)										
04	Glass Crack (Minor defect)	 <p style="text-align: center;">Crack is potential to enlarge, any type is not allowed.</p>										
05	Glass Chipping Pad Area: (Minor defect)	 <table border="1" style="margin-left: auto; margin-right: auto;"> <thead> <tr> <th style="width: 60%;">Length and Width</th> <th style="width: 40%;">Acc. Qty</th> </tr> </thead> <tbody> <tr> <td style="text-align: center;">$c > 3.0, b < 1.0$</td> <td style="text-align: center;">1</td> </tr> <tr> <td style="text-align: center;">$c < 3.0, b < 1.0$</td> <td style="text-align: center;">3</td> </tr> <tr> <td colspan="2" style="text-align: center;">$a < \text{Glass Thickness}$</td> </tr> </tbody> </table>	Length and Width	Acc. Qty	$c > 3.0, b < 1.0$	1	$c < 3.0, b < 1.0$	3	$a < \text{Glass Thickness}$			
Length and Width	Acc. Qty											
$c > 3.0, b < 1.0$	1											
$c < 3.0, b < 1.0$	3											
$a < \text{Glass Thickness}$												
06	Glass Chipping Rear of Pad Area: (Minor defect)	 <table border="1" style="margin-left: auto; margin-right: auto;"> <thead> <tr> <th style="width: 60%;">Length and Width</th> <th style="width: 40%;">Acc. Qty</th> </tr> </thead> <tbody> <tr> <td style="text-align: center;">$c > 3.0, b < 1.0$</td> <td style="text-align: center;">1</td> </tr> <tr> <td style="text-align: center;">$c < 3.0, b < 1.0$</td> <td style="text-align: center;">2</td> </tr> <tr> <td style="text-align: center;">$c < 3.0, b < 0.5$</td> <td style="text-align: center;">4</td> </tr> <tr> <td colspan="2" style="text-align: center;">$a < \text{Glass Thickness}$</td> </tr> </tbody> </table>	Length and Width	Acc. Qty	$c > 3.0, b < 1.0$	1	$c < 3.0, b < 1.0$	2	$c < 3.0, b < 0.5$	4	$a < \text{Glass Thickness}$	
Length and Width	Acc. Qty											
$c > 3.0, b < 1.0$	1											
$c < 3.0, b < 1.0$	2											
$c < 3.0, b < 0.5$	4											
$a < \text{Glass Thickness}$												
07	Glass Chipping Except Pad Area: (Minor defect)	 <table border="1" style="margin-left: auto; margin-right: auto;"> <thead> <tr> <th style="width: 60%;">Length and Width</th> <th style="width: 40%;">Acc. Qty</th> </tr> </thead> <tbody> <tr> <td style="text-align: center;">$c > 3.0, b < 1.0$</td> <td style="text-align: center;">1</td> </tr> <tr> <td style="text-align: center;">$c < 3.0, b < 1.0$</td> <td style="text-align: center;">2</td> </tr> <tr> <td style="text-align: center;">$c < 3.0, b < 0.5$</td> <td style="text-align: center;">4</td> </tr> <tr> <td colspan="2" style="text-align: center;">$a < \text{Glass Thickness}$</td> </tr> </tbody> </table>	Length and Width	Acc. Qty	$c > 3.0, b < 1.0$	1	$c < 3.0, b < 1.0$	2	$c < 3.0, b < 0.5$	4	$a < \text{Glass Thickness}$	
Length and Width	Acc. Qty											
$c > 3.0, b < 1.0$	1											
$c < 3.0, b < 1.0$	2											
$c < 3.0, b < 0.5$	4											
$a < \text{Glass Thickness}$												

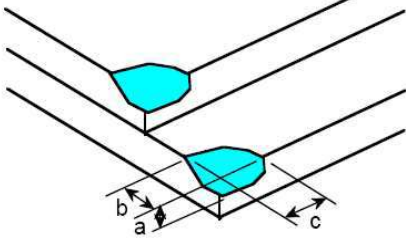
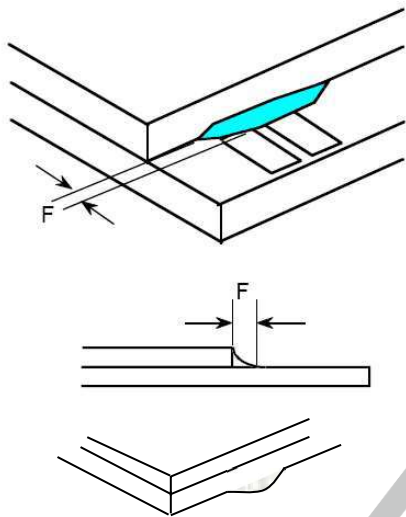
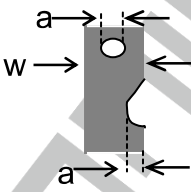
08	<p>Glass Corner Chipping: (Minor defect)</p> 	<table border="1" style="width: 100%; border-collapse: collapse;"> <tr> <th style="width: 50%;">Length and Width</th> <th style="width: 50%;">Acc. Qty</th> </tr> <tr> <td style="text-align: center;">$c < 3.0, b < 3.0$</td> <td style="text-align: center;">Ignore</td> </tr> <tr> <td colspan="2" style="text-align: center;">$a < \text{Glass Thickness}$</td> </tr> </table>	Length and Width	Acc. Qty	$c < 3.0, b < 3.0$	Ignore	$a < \text{Glass Thickness}$			
Length and Width	Acc. Qty									
$c < 3.0, b < 3.0$	Ignore									
$a < \text{Glass Thickness}$										
09	<p>Glass Burr: (Minor defect)</p> 	<table border="1" style="width: 100%; border-collapse: collapse;"> <tr> <th style="width: 50%;">Length</th> <th style="width: 50%;">Acc. Qty</th> </tr> <tr> <td style="text-align: center;">$F < 1.0$</td> <td style="text-align: center;">Ignore</td> </tr> </table> <p>Glass burr don't affect assemble and module dimension.</p>	Length	Acc. Qty	$F < 1.0$	Ignore				
Length	Acc. Qty									
$F < 1.0$	Ignore									
10	<p>FPC Defect: (Minor defect)</p> 	<p>10.1 Dent, pinhole width $a < w/3$. (w: circuitry width.)</p> <p>10.2 Open circuit is unacceptable.</p> <p>10.3 No oxidation, contamination and distortion.</p>								
11	<p>Bubble on Polarizer (Minor defect)</p>	<table border="1" style="width: 100%; border-collapse: collapse;"> <tr> <th style="width: 50%;">Diameter</th> <th style="width: 50%;">Acc. Qty</th> </tr> <tr> <td style="text-align: center;">$\varphi \leq 0.30$</td> <td style="text-align: center;">Ignore</td> </tr> <tr> <td style="text-align: center;">$0.30 < \varphi \leq 0.50$</td> <td style="text-align: center;">$N \leq 4$</td> </tr> <tr> <td style="text-align: center;">$0.50 < \varphi$</td> <td style="text-align: center;">$N = 0$</td> </tr> </table>	Diameter	Acc. Qty	$\varphi \leq 0.30$	Ignore	$0.30 < \varphi \leq 0.50$	$N \leq 4$	$0.50 < \varphi$	$N = 0$
Diameter	Acc. Qty									
$\varphi \leq 0.30$	Ignore									
$0.30 < \varphi \leq 0.50$	$N \leq 4$									
$0.50 < \varphi$	$N = 0$									

12	Dent on Polarizer (Minor defect)	<table border="1" style="margin-left: auto; margin-right: auto;"> <tr> <td style="text-align: center;">Diameter</td> <td style="text-align: center;">Acc. Qty</td> </tr> <tr> <td style="text-align: center;">$\varphi \leq 0.25$</td> <td style="text-align: center;">Ignore</td> </tr> <tr> <td style="text-align: center;">$0.25 < \varphi \leq 0.50$</td> <td style="text-align: center;">$N \leq 5$</td> </tr> <tr> <td style="text-align: center;">$0.50 < \varphi$</td> <td style="text-align: center;">None</td> </tr> </table>	Diameter	Acc. Qty	$\varphi \leq 0.25$	Ignore	$0.25 < \varphi \leq 0.50$	$N \leq 5$	$0.50 < \varphi$	None
Diameter	Acc. Qty									
$\varphi \leq 0.25$	Ignore									
$0.25 < \varphi \leq 0.50$	$N \leq 5$									
$0.50 < \varphi$	None									
13	Bezel	<p>13.1 No rust, distortion on the Bezel.</p> <p>13.2 No visible fingerprints, stains or other contamination.</p>								
14	Touch Panel	<p>D: Diameter W: width L: length</p> <p>14.1 Spot: $D < 0.25$ is acceptable $0.25 \leq D \leq 0.4$ 2dots are acceptable and the distance between defects should more than 10 mm. $D > 0.4$ is unacceptable</p> <p>14.2 Dent: $D > 0.40$ is unacceptable</p> <p>14.3 Scratch: $W \leq 0.03$, $L \leq 10$ is acceptable, $0.03 < W \leq 0.10$, $L \leq 10$ is acceptable Distance between 2 defects should more than 10 mm. $W > 0.10$ is unacceptable.</p>								
15	LCD Ripple	<p>Touch the touch panel, cannot see the LCD ripple.</p> <p>Pen: R 0.8mm silicon rubber.</p> <p>Operation Force:120g</p>								
16	PCB	<p>16.1 No distortion or contamination on PCB terminals.</p> <p>16.2 All components on PCB must same as documented on the BOM/component layout.</p> <p>16.3 Follow IPC-A-600F.</p>								
17	Soldering	<p>Follow IPC-A-610C standard</p>								
18	Electrical Defect (Major defect)	<p>The below defects must be rejected.</p> <p>18.1 Missing vertical / horizontal segment,</p> <p>18.2 Abnormal Display.</p> <p>18.3 No function or no display.</p> <p>18.4 Current exceeds product specifications.</p> <p>18.5 LCD viewing angle defect.</p> <p>18.6 No Backlight.</p> <p>18.7 Dark Backlight.</p> <p>18.8 Touch Panel no function.</p>								

Remark: LCD Panel Broken shall be rejected. Defect out of LCD viewing area is acceptable.

10.7. Classification of Defects

10.7.1. Visual defects (Except no / wrong label) are treated as minor defect and electrical defect is major.

10.7.2. Two minor defects are equal to one major in lot sampling inspection.

10.8. Identification/marketing criteria

Any unit with illegible / wrong /double or no marking/ label shall be rejected.

10.9. Packing

10.9.1. There should be no damage of the outside carton box, each packaging box should have one identical label.

10.9.2. Modules inside package box should have compliant mark.

10.9.3. All direct package materials shall offer ESD protection.

Note1: Bright dot is defined as the defective area of the dot is larger than 50% of one sub-pixel area.

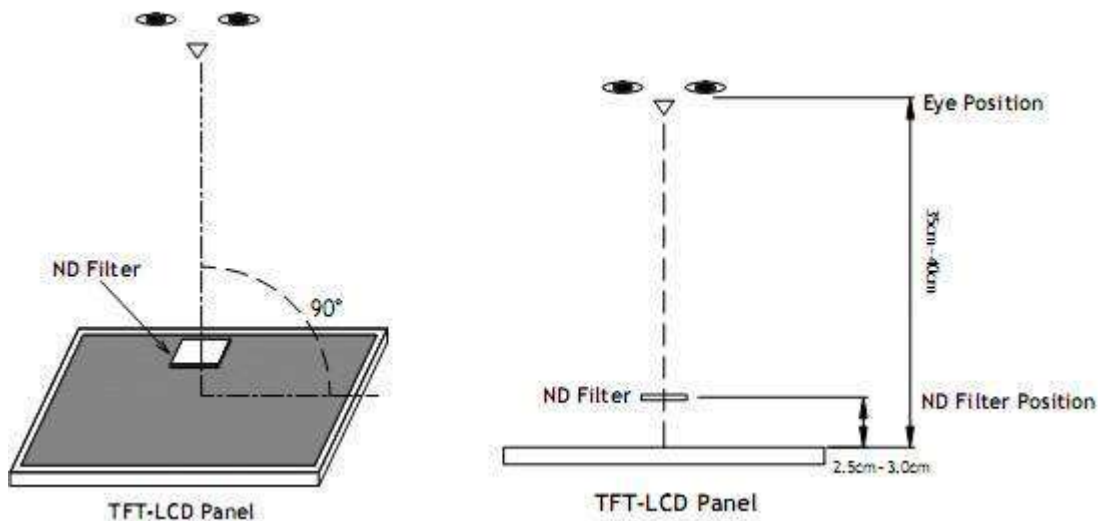

Bright dot: The bright dot size defect at black display pattern. It can be recognized by 2% transparency of filter when the distance between eyes and panel is $350\text{mm} \pm 50\text{mm}$.

Dark dot: Cyan, Magenta or Yellow dot size defect at white display pattern. It can be recognized by 5% transparency of filter when the distance between eyes and panel is $350\text{mm} \pm 50\text{mm}$.

Note2: Mura on display which appears darker / brighter against background brightness on parts of display area.

11. Reliability Specification

No	Item	Condition	Quantity	Criteria
1	High Temperature Operating	85°C, 120Hrs	2	GB/T2423.2-2008
2	Low Temperature Operating	-30°C, 120Hrs	2	GB/T2423.1-2008
3	High Humidity Storage	60°C, 90%RH, 120Hrs	2	GB/T2423.3-2006
4	High Temperature Storage	90°C, 120Hrs	2	GB/T2423.2-2008
5	Low Temperature Storage	-40°C, 120Hrs	2	GB/T2423.1-2008
6	Thermal Cycling Test	-30°C, 60min~80°C, 60min, 20 cycles.	2	GB/T2423.2-2012
7	Packing vibration	Frequency range:10Hz~50Hz Acceleration of gravity:5G X, Y, Z 30 min for each direction.	2	GB/T5170.1-2009
8	Electrical Static Discharge	Air: ±8KV 150pF/330Ω 5 times	2	GB/T17626.2-2006
		Contact: ±4KV 150pF/330Ω 5 times		
9	Drop Test (Packaged)	Height:80 cm, 1 corner, 3 edges, 6 surfaces.	2	GB/T2423.8-1995

Note1. After the reliability test, the product only guarantee function normally without any fatal defect (non-display, line defect, abnormal display). All the cosmetic specification is judged before the reliability test.

Note2. Total current Consumption should be below double of initial value.

Note3. One product only can borne one item of reliability test. Can not take same single one product to do different reliability test .

Note4. All adjustment of display are performed after temperature of product back to room temperature and under static situation for 2 hrs.

Note5. Under no condensation of dew

12. Precautions and Warranty

12.1.Safety

- 12.1.1. The liquid crystal in the LCD is poisonous. Do not put it in your mouth. If the liquid crystal touches your skin or clothes, wash it off immediately using soap and water.
- 12.1.2. Since the liquid crystal cells are made of glass, do not apply strong impact on them. Handle with care.

12.2.Handling

- 12.2.1. Reverse and use within ratings in order to keep performance and prevent damage.
- 12.2.2. Do not wipe the polarizer with dry cloth, as it might cause scratch. If the surface of the LCD needs to be cleaned, wipe it swiftly with cotton or other soft cloth soaked with petroleum IPA, do not use other chemicals.

12.3.Storage

- 12.3.1. Do not store the LCD module beyond the specified temperature ranges.
- 12.3.2. Strong light exposure causes degradation of polarizer and color filter

12.4.Metal Pin (Apply to Products with Metal Pins)

12.4.1. Pins of LCD and Backlight

13.4.1.1 Solder tip can touch and press on the tip of Pin LEAD during the soldering

13.4.1.2 Recommended Soldering Conditions

Solder Type: Sn96.3~94-Ag3.3~4.3-Cu0.4~1.1

Maximum Solder Temperature: 370 °C

Maximum Solder Time: 3s at the maximum temperature

Recommended Soldering Temp: 350±20 °C

Typical Soldering Time: ≤3s

13.4.1.3 Solder Wetting

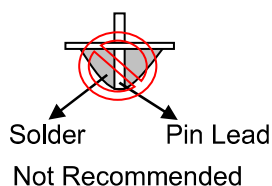
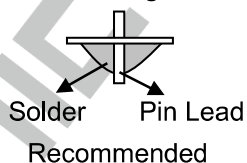

12.4.2. Pins of EL

13.4.2.1 Solder tip can touch and press on the tip of EL leads during soldering.

13.4.2.2 No Solder Paste on the soldering pad on the motherboard is recommended.

13.4.2.3 Recommended Soldering Conditions

Solder type: Nippon Alimit Leadfree SR-34, size 0.5mm

Recommended Solder Temperature: 270~290 °C

Typical Soldering Time: ≤2s

Minimum solder distance from EL lamp (body):2.0mm

13.4.2.4 No horizontal press on the EL leads during soldering.

13.4.2.5 180° bend EL leads three times is not allowed.

13.4.2.6 Solder Wetting

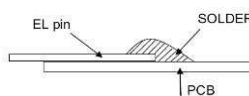

Recommended

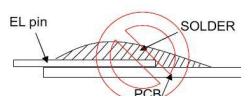

Not Recommended

13.4.2.7 The type of the solder iron:

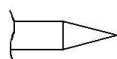

Recommended

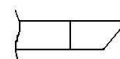

Not Recommended

13.4.2.8 Solder Pad

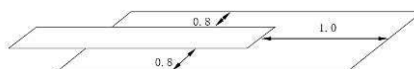

12.5. Operation

- 12.5.1. Do not drive LCD with DC voltage
- 12.5.2. Response time will increase below lower temperature
- 12.5.3. Display may change color with different temperature
- 12.5.4. Mechanical disturbance during operation, such as pressing on the display area, may cause the segments to appear “fractured”.
- 12.5.5. Do not connect or disconnect the LCM to or from the system when power is on.
- 12.5.6. Never use the LCM under abnormal condition of high temperature and high humidity.
- 12.5.7. Module has high frequency circuits. Sufficient suppression to the electromagnetic interface shall be done by system manufacturers. Grounding and shielding methods may be important to minimize the interference.
- 12.5.8. Do not display the fixed pattern for long time (we suggest the duration time not longer than half an hour) because it may develop image sticking due to the TFT structure.

12.6. Static Electricity

- 12.6.1. CMOS LSIs are equipped in this unit, so care must be taken to avoid the electro-static charge, by ground human body, etc.
- 12.6.2. The normal static prevention measures should be observed for work clothes and benches.
- 12.6.3. The module should be kept into anti-static bags or other containers resistant to static for storage.

12.7. Limited Warranty

- 12.7.1. Our warranty liability is limited to repair and/or replacement. We will not be responsible for any consequential loss.
- 12.7.2. If possible, we suggest customer to use up all modules in six months. If the module storage time over twelve months, we suggest that recheck it before the module be used.
- 12.7.3. After the product shipped, any product quality issues must be feedback within three months, otherwise, we will not be responsible for the subsequent or consequential events.

13. Packaging

TBD

SOLONIC CONFIDENTIAL